

## The Strange Nature of Quantum Perception: To See a Photon, One Must *Be* a Photon

Steven M. Rosen

*College of Staten Island, City University of New York*

This paper takes as its point of departure recent research into the possibility that human beings can perceive single photons. In order to appreciate what quantum perception may entail, I first explore several of the leading interpretations of quantum mechanics, then consider an alternative view based on the ontological phenomenology of Maurice Merleau-Ponty and Martin Heidegger. Next, the philosophical analysis is brought into sharper focus by employing a perceptual model, the Necker cube, augmented by the topology of the Klein bottle. This paves the way for addressing in greater depth the paper's central question: Just what would it take to observe the quantum reality of the photon? In formulating an answer, I examine the nature of scientific objectivity itself, along with the paradoxical properties of light. The conclusion reached is that quantum perception requires a new kind of observation, one in which the observer of the photon adopts a concretely self-reflexive observational posture that brings her into close ontological relationship with the observed.

Keywords: quantum perception, Necker cube, topological phenomenology

For many decades it has been suspected that the human visual system is sensitive enough to be able to detect single particles of light. Only recently has this hypothesis been confirmed. Using a quantum light source capable of generating individual photons, Tinsley, Molodtsov, Prevedel, Wartmann, Espigulé-Pons, Lauwers, and Vaziri (2016) demonstrated that human beings can indeed detect solitary photons. The finding has gained additional support in the laboratory of Paul Kwiat and Rebecca Holmes (Holmes, Victoria, Ranxiao, and Kwiat, 2018). It is noteworthy that researchers pursuing this line of investigation have not limited themselves to verifying the detectability of single photons but have set their sights on determining

---

This article was inspired by a private communication from Beth Macy informing me of recent breakthroughs in single-photon vision research. I also gratefully acknowledge that the paper's subtitle was suggested by Marlene Schiwy in the course of informal discussions about the issues involved. Correspondence concerning this article should be addressed to Steven M. Rosen, Ph.D., 104–2890 Point Grey Road, Vancouver, B.C., V6K 1A9, Canada. Email: stevenrosen@shaw.ca

whether human vision can be pushed even further in the attempt “to probe the very foundations of quantum mechanics” (Ananthaswamy, 2018, para. 2).

The standard approach to quantum mechanics is the Copenhagen interpretation. This outlook lends itself to the view that there is in fact no way of knowing the underlying reality giving rise to observed photons. The Copenhagen interpretation does posit a probabilistic quantum wave in which particle states are superposed, rather than the particle being definitively given in one state as opposed to another. When the particle is observed, the wave “collapses”; it is reduced so that the particle now appears in just a single state. Yet according to the Copenhagen approach, the quantum probability wave has no physical reality per se but is only a mathematical function. On this view, the wave does not exist in a concrete sense but is merely the form taken by the abstract equation used to generate practical predictions about the behavior of particles. Nevertheless, research efforts such as those reported on by Ananthaswamy (2018, para. 2) would challenge the Copenhagen interpretation by exploring the possibility of actually observing the quantum wave. Thus, in speaking of the prospect of going beyond the detection of single photons to test “the perception of superposition states,” Holmes et al. (2018) are indicating that we may be able to detect the photon wave while its quantum states are still superposed, before the wave collapses to give mutually exclusive states.

But there is a significant obstacle to this research, for it is by no means certain that a photon transmitted to the eye of an observer will actually register in the retina and be sent on to the brain for perception. Describing the work of physicist Alipasha Vaziri, Castelveccchi (2016) notes that “more than 90% of photons that enter the front of the eye never even reach a rod cell, because they are absorbed or reflected by other parts of the eye” (para. 7). Other experiments with single-photon detection encounter the same kind of drawback. Holmes et al. (2018) sum up the problematic nature of these studies: “The primary challenge for ... single-photon vision experiments will be the low probability that a photon is transmitted to the photoreceptors and detected in any given experimental trial (perhaps 5–10%, assuming a perfectly efficient source), and the corresponding requirement for a very large number of experimental trials” (Conclusions section, para. 1) to determine whether the statistics bear out that single photons are actually being detected, however small the effect.

In experiments such as these, certain tacit assumptions are made in accordance with long-held habits of observation. Whether hoping to observe a photon in a single state or as the superposed photon states of the quantum wave, the observer viewing the particle display is poised to encounter an object appearing in the space stretched out before him. The observer’s implicit posture is thus externally oriented, set to take in what lies “out there,” with the observer himself set apart from what is observed. This is how we normally take things in. We have been doing this for hundreds of years, both in everyday observation, and, especially, in

empirical science. What I venture to suggest in this article is that, while we might indeed come to effectively observe (perhaps with special training) the quantum substrate underlying the photon, we will only be able to do so by changing the default setting long relied upon for our manner of observation.

Before we can fully appreciate what quantum perception might entail, it will be necessary to examine the quantum world in greater depth. Below I explore various interpretations of quantum mechanics and their philosophical implications. Then, with this conceptual spadework behind us, I offer a specific model of quantum perception that eventually leads us back to our ultimate question of just what is required for the observation of quantum reality.

### Exploring the Quantum Dimension

In a 1964 lecture, physicist Richard Feynman famously declared: “I think I can safely say that nobody understands quantum mechanics” (1967, p. 129). This appraisal seems to have held up fairly well. I noted above that the minimalist Copenhagen interpretation is the standard approach to quantum mechanics. From its inception almost a century ago, the Copenhagen school apparently has been content to leave open the question of what quantum phenomena actually mean. The equations are not expected to provide insight into the physical structure of quantum reality but only to effectively predict particle behavior. As physicist David Mermin put it, “If I were forced to sum up in one sentence what the Copenhagen interpretation says to me, it would be ‘Shut up and calculate!’” (1989, p. 9). It is not that alternatives to Copenhagen have not been offered. The proposals include a range of mind-independent (realist) views of the quantum domain, such as Everett et. al.’s “many worlds” interpretation (1973), Bohm’s pilot wave theory (1952), and the more recent Ghirardi–Rimini–Weber (GRW) observer-independent model of wave collapse (1986). There are also mind-dependent (immaterialist or idealist) approaches such as those of von Neumann–Wigner (von Neumann, 1932; Wigner, 1961), Wheeler (1990), and Goswami (1995). Nevertheless, after many decades, “the Copenhagen interpretation still reigns supreme” (Schlosshauer, Kofler, and Zeilinger, 2013). What this is telling us, in effect, is that the quantum domain remains a black box to most theoretical physicists. It is telling us what Feynman told us 50 years earlier: that a widely accepted understanding of quantum reality has not yet been achieved.

#### *Mind-Independent and Mind-Dependent Interpretations of Quantum Mechanics*

Let us take a deeper look at the Copenhagen interpretation. Is it actually as non-committal as it claims to be with regard to the nature of quantum reality? At the level of its explicit content, the answer is yes: advocates of Copenhagen maintain their silence on the quantum phenomenon per se, treating it as a black box.

However, when we consider the form taken by Copenhagen mathematics, we see that it implicitly enforces the same paradigm that underlies mind-independent, objective realist interpretations of quantum mechanics.

The realist paradigm is intuitively compelling in that it accords with our everyday experience of the world. What is real is seen to lie objectively “out there” in space, existing independently of the subject who perceives it. For the scientist employing this paradigm of “object-in-space-before-subject” (Rosen, 2004, 2008, 2015), space must be continuous, for it is only in a continuum that precise observations and measurements can be made of the objects and events appearing before the observing subject. The inherent *discontinuity* we find in quantum phenomena calls objective measurement into question, since it implies that, in microspace, in fact we *cannot* determine unequivocally the position of a system. How does quantum mechanics respond to this challenge?

A central feature of the quantum theoretic formalism employed by the Copenhagen school is analysis by probability. When quantum mechanics was confronted with the inability to precisely determine a particle’s location in space, it did not merely resign itself to the lack of continuity that creates this fundamental uncertainty. Instead of allowing the conclusion that a microsystem in principle cannot occupy a completely distinct position — which would be tantamount to admitting that microspace is not completely continuous — a multiplicity of continuous spaces was axiomatically invoked to account for the “probable” positions of the particle: “it” is locally “here” with a certain probability, or “there” with another. This collection of spaces is known as *Hilbert space*.

Just how effectively does Hilbert space preserve continuity and the underlying objectivism with which it is coupled? Each subspace of the multi-space expression is made continuous within itself to uphold the mutual exclusiveness of the alternative positions of the observed particle. Such subspaces must be disjoint with respect to each other, their unity being imposed externally, by fiat, rather than being of an internal, intuitively compelling order. So, in the name of maintaining mathematical continuity, a rather extravagantly discontinuous state of affairs is actually permitted in the standard formalism for quantum mechanics, an indefinitely large aggregate of essentially discrete, disunited spaces.

It is evident then, that continuity actually is not successfully maintained in quantum mechanics. Despite the artificial semblance of it, on the subtler level of the form that quantum theory takes, continuity is denied (Rosen, 1994, 2004, 2008). As a matter of fact, if we were to follow the full development of quantum mechanics, we would see that, in the end, even the *semblance* of continuity is lost in the failed attempt to arrive at an effective account of quantum gravity. For, at the submicroscopic scale where the challenge of unifying the quantum forces with gravitation is played out, infinite probability values turn up that render the equations useless. I’ve gone into this in detail elsewhere (e.g., Rosen, 2008) and will not expound further on it here.

If the implicit objectivism of the Copenhagen mathematical program undermines the ability to adequately account for phenomena that do not conform to the expectations of objective realism, openly realist approaches to quantum mechanics certainly fare no better. Explicit forms of realism (Everett's "many worlds" interpretation, Bohm's pilot wave theory, etc.), in adhering to the paradigm of object-in-space-before-subject, thus can shed little light on the meaning of quantum reality.

Before proceeding to consider the mind-dependent approach to quantum mechanics, I want to emphasize that the microphysical challenge to classical continuity is at once a challenge to the separation of subject and object. Said separation was a defining feature of the fourteenth century European Renaissance. What the Renaissance brought forth was not only the emergence of a new space (the continuum) but also a newly autonomous subject who stood apart from that space and the objects therein. This is reflected in Descartes' dualistic philosophy, which posited the object as *res extensa*, a thing extended in space, and the subject as *res cogitans*, a "thinking thing" entirely without spatial extension, thus transcendent of space. By the end of the seventeenth century, the classical formulation was firmly entrenched in human affairs and had assumed the status of a self-evident intuition. All human perception was now generally organized in terms of objects appearing in space before the gaze of detached subjects.

This new reality was epitomized in the subsequent rise of empirical science. Here the spatial continuum rendered the object precisely measurable while, at the same time, the object was divided from the transcendent subject who performed the measurement as if from outside of space. Because this pure act of measurement was assumed to leave the measured object completely unchanged, the observed properties of the object were regarded as reflecting what the object really was, independent of any distortive influence a less pristine, space-bound observer might exert. Thus the operations of empirical science were grounded in a mind-independent realism.

The phenomena of quantum physics that began to be investigated at the opening of the twentieth century fly in the face of realist assumptions about the world. The microphysical loss of continuity is accompanied by a merging of subject and object wherein the subject can no longer be taken as detached from a spatial continuum within which objects are contained. In quantum mechanics, the return to earth of the observing subject registers in the fact that the energy that must be transferred to a system in order to observe it, disturbs that system significantly. It was always tacitly granted that observing a system affects it, but the influence is negligible in macroscopic interactions and therefore could be overlooked in the classical idealization of the observer. Microworld observation is different. Here the idealized aloofness of the observer must give way to the recognition of its intimate interaction with the observed.

Of course, the long-dominant paradigm of mind-independence was not simply relinquished. Just as a semblance of continuity could be maintained in confronting quantum discontinuity, a way was found to maintain mind-independent “objectivity” when confronted with the quantum-level intimacy of subject and object.

There is a substantial difference between pre-quantum and quantum versions of the classical posture. In the former, we have objective events occurring in three-dimensional space before the detached gaze of an idealized subject. In the latter — where the observer’s close involvement with the observed cannot merely be discounted, subjectivity itself is taken as object, with the “object” now being regarded as an *observational* event transpiring in  $n$ -dimensional Hilbert space. Whereas three-dimensional events are concretely observable, the dimensions of Hilbert space are sheer abstractions. And the idealized quantum observer of these  $n$ -dimensional acts of observation is a further step removed from the concrete reality that constrained his Newtonian predecessor. Nevertheless, in both cases, the traditional stance is strictly maintained. In both, we have object-in-space-before-subject.

Thus objectivist quantum mechanics implicitly transforms the old subject into an object cast before a more abstract, higher-order subject.<sup>1</sup> In effect, the quantum mechanical researcher assumes a superordinate vantage point from which he is able to consider alternative acts of classical observation and weight them probabilistically, with each act corresponding to a different subspace of the Hilbert space. Here the “objects” to be analyzed are not mere concrete substances but observations themselves — what Max Planck called the “run of our perceptions” (quoted in Jahn and Dunne, 1984, p. 9). If the “scientific objectivity” of the quantum mechanical analysis of observation is to be maintained, the implicit observational activity of the *analyst* of observation must itself be exempted from the analysis. That is to say, two ontologically distinct levels of observational or subjective activity have to exist: that which is to be analyzed, and that through which the analysis is to take place. The former is constituted by the old subjective activity that is now objectified within the framework of the Hilbert space, whereas the latter corresponds to the more abstract, higher-order, wholly implicit activity of the quantum mechanical subject standing outside of Hilbert space. It is clear that this subject assumes the same detached, “purely objective” stance as did his Newtonian forerunner. Still operative in its essential relations is the basic formula of object-in-space-before-subject, though the natural intuitive appeal the formula had held in the classical context is now stretched into a counter-intuitive abstraction that, in the end, founders on the rocks of quantum gravity, as I intimated above.

---

<sup>1</sup> Einsteinian relativity performs the same sort of transformation. That is why Einstein’s theory is no more “relative” than quantum mechanics is “subjective.” See my comparative analysis of relativity and quantum mechanics (Rosen, 2015).

Summing up, the quantum world entails a loss of spatial continuity coupled with an intimate fusion of subject and object that defies the classical order and its underlying objectivist paradigm. We have seen the means used by physicists to resuscitate this paradigm and I have questioned the effectiveness of these attempts. My conclusion is that the objectivist, mind-independent tradition does not appear equal to the task of accounting for quantum reality.

What can we say about the mind-dependent interpretation of quantum mechanics? This approach to modern physics puts mind before matter in attempting to understand the quantum world. Thus, according to the von Neumann–Wigner hypothesis (von Neumann, 1932; elaborated upon in Wigner, 1961, 1967), consciousness is necessary for collapsing the quantum wave. And in John Wheeler’s (1990) hypothesis, the physical universe arises from information. How has the mind-dependent view been received by the scientific community? In 2011, an informal poll was conducted of physicists, mathematicians, and philosophers attending a physics conference and it was found that, of the 33 participants, only two were favorably disposed toward mind-dependence (see Schlosshauer et al., 2013). Why the distinct lack of enthusiasm for this view?

I noted above that the mind-independent paradigm is aligned with our everyday experience of reality as lying objectively “out there.” Because the contrasting mind-dependent approach posits the equal or superordinate reality of the mind “in here,” it runs counter to commonsense intuition and is therefore harder to accept. But the objection to the mind-dependent perspective runs deeper than that.

If the mind-dependent notion that consciousness causes wave collapse is taken in the dualistic spirit of Cartesian interactionism, the notorious mind–body problem arises: How can such ontologically disparate entities as mind and matter interact? How is it possible for an entity without extension in space (*res cogitans*) to exert an influence on an entity extended in space (*res extensa*)? Descartes offered no convincing explanation for how this could happen nor has any been provided since his time.

Nevertheless, the mind-dependent view may alternatively be seen as an expression of the monistic philosophy of immaterialism. Direct metaphysical assertions of this doctrine (e.g., Goswami, 1995) have sometimes been met with skepticism and even dismissed as “quantum quackery” (Shermer, 2005), at least in part because many physicists find it uncomfortable to place physics squarely within an overarching metaphysical or religious context. A more subtle form of immaterialism was noted above, one that is more acceptable to mainstream physics: John Wheeler’s “it from bit” proposition that the material world is built up from immaterial units of information. As Wheeler puts it, “every physical quantity, every it, derives its ultimate significance from bits, binary yes-or-no indications, a conclusion which we epitomize in the phrase, *it from bit*” (1990, p. 309). Philosopher Christopher Timpson (2010) examines this proposition at length.

Timpson begins by noting that, on first appraisal, an informational approach to quantum mechanics does seem to resolve its central problem of measurement. He gives as an example the thought experiment known as “Wigner’s friend” (which is related to Schrodinger’s famous cat paradox). Physicist Eugene Wigner has a colleague doing an experiment with particles in a closed laboratory. Wigner himself is outside the laboratory. When his friend reaches the point of measuring the spin state of a particle, the superposition of particle states collapses accordingly to yield a definite outcome. But Wigner himself is not privy to this finding so that, for him, the particle states are still in superposition. The question then concerns the time at which the superposition collapses. Was it when the friend made his measurement, or was it later, when Wigner became aware of the results? As Timpson puts it, “Does Wigner’s friend see a definite outcome, or is he left suspended in limbo until Wigner opens the door to say hello?” This is the kind of paradox that arises when the quantum state is taken as representing “how things are in the world.” But if we take it as representing the “information somebody possesses,” the paradox evidently dissolves. There is no disagreement on when the collapse objectively occurs because the collapse is not taken as occurring objectively out there in the world. Wigner and his friend simply have access to different information and when Wigner’s friend tells him what he observed, Wigner will update what he knows about the quantum state. This will occasion no mysterious change out in the world, since the update strictly concerns the information one has. Having laid out the informational interpretation in this way, Timpson goes on to express his doubts.

Echoing physicist John Bell, Timpson suggests the necessity of asking what quantum mechanical information *is about*. If it is simply about what the outcome of experiments will be, then we slide back into the Copenhagen school’s noncommittal, instrumentalist approach to the meaning of the quantum world, which Timpson rightly finds uninteresting. The other alternative is that the information is about the “properties of a system which are possessed prior to measurement and which aren’t described by the quantum state (in this case because the state doesn’t have a world-describing role)” [2010, p. 214]. Timpson views this interpretation of quantum information as implicitly leading us back to the search for variables hidden within the probabilistic quantum state. For Timpson, such a move is self-defeating because hidden variables have been found to behave “very badly... ([displaying] non-locality [and] contextuality)” and “the whole point of taking the quantum state as information was to mollify its bad behaviour, its jumping here and there we know not when, its nonlocal collapse” (p. 214). Timpson’s final conclusion: “The informational approach to the quantum state seems unable to survive the hidden variables/instrumentalism dilemma; and the thought that quantum information theory does lend support to a form of immaterialism really seems to have very little to commend it” (p. 225).



### *The Husserlian Interpretation*

In the previous section, I mentioned a different version of the mind-dependent view, namely, the von Neumann–Wigner view of quantum mechanics, which was further developed by Wigner (1961, 1967). The idea commonly attributed to Wigner is that the physical quantum wave is collapsed by non-physical consciousness. In the absence of any real understanding of how this could happen, the action of consciousness takes on the appearance of operating as a phantasmal *deus ex machina*, inexplicably swooping in to effect change in the material world. Thus, it seemed to many physicists (e.g., Putnam, 1964; Shimony, 1963) that, with approaches like Wigner’s, the specter of Cartesian interactionism haunts the scene.

Philosopher Steven French (2019) challenges this reading of Wigner’s position. According to French, criticism of Wigner has been based on the mistaken assumption that, in speaking of the action of consciousness, Wigner was adhering to the naïve mind–body dualism in which consciousness acts on the physical world from outside it. French maintains that, in fact, Wigner had been influenced by the phenomenological philosophy of Husserl wherein consciousness is regarded as acting *immanently*.

In French’s interpretation of Wigner, consciousness enters the quantum experiment not as some phantom from the beyond, but through the auspices of the experimenter’s “objectifying act of reflection” (p. 11). French holds that, in observing the quantum system, the observer is introspectively aware of herself doing so and, through observing herself in relation to the system being observed, she objectifies that system, i.e., reduces the wave function to a definite value. To support this view, French cites London and Bauer (1939/1983), the phenomenologically oriented physicists who had influenced Wigner’s outlook:

... it is not a mysterious interaction between the apparatus and the object that produces a new  $\gamma$  for the system during the measurement. It is only the consciousness of an “I” who can separate himself from the former function  $\Psi(x, y, z)$  and, by virtue of his observation, set up ... a new objectivity in attributing to the object henceforward a new function  $\gamma(x) = uk(x)$ . (1983, p. 252)

By thus internalizing consciousness, it appears to be brought into the quantum picture without falling prey to the problem of Cartesian interaction. This is surely an important step in addressing the shortcomings of the old realist paradigm. The classical inability to account for the action of consciousness on matter is phenomenologically remedied by regarding consciousness and the quantum system as correlated poles — the “subject-pole” and the “object-pole” — of a single relational act (see French, 2019, p. 11). However, I venture to suggest that, in the Husserlian approach to phenomenology, there is a sense in which the old paradigm actually persists. I pointed out earlier that when physicists were confronted with the

radical interaction of subject and object found in the quantum world, rather than relinquish the objectivist worldview upon which science had been built, they introduced a form of objectivism in which the subject was transformed into a new object, one implicitly cast before a higher-order subject. With the “objectifying act of reflection” carried out in the Husserlian quantum laboratory, a subtler version of the same sort of objectification is evidently enacted.

Proponents of traditional objectivism might be inclined to view Husserlian phenomenology as a lapse into fuzzy subjectivism. This cannot be further from the truth. Husserl was in fact seeking *greater* objectivity than what had been achieved in the natural sciences. In advocating “philosophy as rigorous science” (Husserl, 1911/1965, p. 71), he saw naturalism as contradicting itself because it operates subjectively to project an external reality that is then naively assumed to be simply independent of its subjective action. The projection must be withdrawn, says Husserl. In a fully objective science, “objectivity...must precisely become evident purely from consciousness itself” (1911/1965, p. 90). As regards the “objectifying act of reflection” that takes place in the quantum laboratory according to the Husserlian interpretation, consciousness applies itself to itself so as to collapse the quantum wave. Elsewhere (Rosen, 2004), I demonstrated that such a self-objectification entails an implicit re-subjectification.

In rejecting empirical objectivism, Husserl dispenses with the exterior space said objectivism requires for the observation and measurement of its objects. He replaces the external dimension with a wholly interior one, a space to be known through intuition rather than through sense perception; one that is neither physical nor empirically psychological but purely logical; a space wherein the perfectly self-consistent operations of consciousness are enacted. Of course, it is consciousness itself that is to observe these operations. Therefore, the observation in question is a *self*-observation, an intuitive self-reflection. And yet, the old categorial division of subject and object is still at play in this immanent realm. For, to know anything objectively, the knower or subject must be detached from what he knows. In the paradigm upon which scientific objectivism relies, the containment of an object in space and the detachment of the subject from that object are integral aspects of the same process: by the same act in which the object is sealed into space, the subject is sealed out, separated from that object. No less does this apply to Husserl’s phenomenological version of scientific objectivism. If Husserl’s “transcendental subject” is to gain purely apodictic knowledge of its object — which, in this case, is itself — it must become detached from that object. The internal division of consciousness into subject-as-object and subject-as-subject is implied in Lauer’s (1965) comment that, for Husserlian phenomenology, “it is the object, not the subject, that determines what science must be,” and that it “is the character of what is to be known, not the character of the knower, that makes phenomenology the only viable philosophical method” (p. 23).

Note the limitation of Husserlian intuition that results from its objectivism. It cannot take in the actual process by which it splits itself into subject-as-object and subject-as-subject. Its grasp is restricted to the object alone, which appears only after the division has occurred. The act of division itself is thus not open to intuitive inquiry but is simply presupposed. Husserlian reflection confines itself to consciousness as objective content, as the objectified subject contained in the interior logical space that has been established. It is in this way that the phenomenological *cogito* is divided, with one part of it — the part to be investigated — constituting an “interior logical object,” and the other part of it — that doing the investigating — entailing a new, higher-order subjectivity that goes uninvestigated. The end result of this is the establishment of a regress that guarantees the incompleteness of Husserl’s “phenomenological reduction.” For, in the attempt to reach objective closure on the “transcendental subject” via the division of consciousness, subjectivity forever evades the grasp of intuition.

What are the implications of Husserlian objectivism for the question of quantum measurement? In the macroscopic quantum laboratory as understood by Steven French, the intuitive act of self-objectification collapses the quantum wave. Yet even though this allows the conclusion that consciousness is the agent of collapse and avoids the problem of Cartesian interaction in drawing this conclusion, it gives us no intuitive grasp of what is actually being collapsed: the quantum wave *per se*. That is because the submicroscopic quantum system defies that to which Husserlian intuition is limited: the macroscopic field of strictly objective relations. We know by now that at the heart of quantum reality is a heretical overlapping of subject and object that no form of objectivism is fully equipped to deal with. Husserlian phenomenology is no exception. But there is an alternative approach to phenomenology that may be better suited for plumbing the quantum depths. And this approach may suggest a mode of perception that can be employed effectively with the extension of perceptual experience to the microworld anticipated in the opening of this paper.

### *Ontological Phenomenology*

Husserl’s epistemological phenomenology was succeeded by the ontological phenomenologies of Heidegger and Merleau–Ponty. In their writings, the emphasis shifts from apodictic knowing to an investigation of being as such (this is especially true in the late works of these philosophers). For our purposes, ontological phenomenology can be seen most essentially as a critique of the classical trichotomy of object-in-space-before-subject. To Merleau–Ponty, the activities of the detached Cartesian subject are idealizing objectifications of the world that conceal the concrete reality of the *lifeworld* (a term Merleau–Ponty borrowed from Husserl but put to different use). Obscured by the lofty abstractions of European science, this earthy realm of lived experience is inhabited by subjects

that are not anonymous, that do not fly above the world, exerting their influence from afar. In the lifeworld, the subject is a fully situated, fully-fledged participant engaging in transactions so intimately entangling that it can no longer rightly be taken as separated either from its objects, or from the worldly context itself. As Heidegger put it, the down-to-earth subject is a *being-in-the-world* (1927/1962).

It is clear that all three terms of the classical formula — object, space, and subject — are affected by this phenomenological move. In the traditional account, objects are taken as simply external to each other and as appearing within a spatial continuum of *sheer* externality, since the continuum is deemed infinitely divisible. As philosopher Milič Čapek put it in questioning the classical notion of space, “no matter how minute a spatial interval may be, it must always be an *interval* separating two points, each of which is *external* to the other” (1961, p. 19). Heidegger thus speaks of conventional space as the “outside-of-one-another’ of the multiplicity of points” (1927/1962, p. 481). The agents operating upon the objects constitute a third kind of externality, acting as they do from a transcendent vantage point beyond the objects in space. It is this privileging of external relations that is counteracted by ontological phenomenology. Notwithstanding the Cartesian idealization of the world, in the underlying *lifeworld* there is no object with boundaries so sharply defined that it is closed off completely from other objects. The lifeworld is characterized instead by the *transpermeation* of objects (their “superposition,” in quantum parlance), by their mutual interpenetration, by the “reciprocal insertion and intertwining of one in the other” (Merleau-Ponty, 1968, p. 138). With objects hence related by way of mutual containment, no *separate* container is required to mediate their relations, as would have to be the case with externally related objects. Objects are therefore no longer to be thought of as contained in space like things in a box, for, in containing each other, they contain themselves. At the same time, it must also be understood that, in the lifeworld, there can be no peremptory division of object and subject. The lifeworld subject — far from being the disengaged, high-flying *deus ex machina* of Descartes or even Husserl’s transcendental subject — finds itself down among the objects as “one of the visibles” (Merleau-Ponty, 1968, p. 135); it is itself always an object to some *other* subject, so that the simple distinction between subject and object is confounded and “we no longer know which sees and which is seen” (p. 139). The ontological grounding of the subject is thus indicative of the close interplay of subject and object in the lifeworld. Generally speaking then, what the move from classical thinking to ontological phenomenology essentially entails is an internalization of the relations among subject, object, and space.

### *The Depth Dimension*

The link between the lifeworld and the quantum world should already be broadly evident. With the former, the classical continuum is supplanted by

an internally constituted space of superposed entities featuring the intimate interaction of subject and object. A more specific articulation of the onto-phenomenological response to the problem of grasping quantum reality can be derived from another work of Merleau-Ponty. In his essay “Eye and Mind” (1964), his concept of *depth* provides an account of dimensionality that permits us to better understand the limitations of Cartesian space and to surpass them.

For Descartes, notes Merleau-Ponty, a dimension is an extensive continuum entailing “absolute positivity” (1964, p. 173). Descartes’ assumption is that space simply is *there*, that it subsists as a positive presence possessing no folds or nuances; no shadows, shadings, or subtle gradations; no internal dynamism. Space is thus taken as the utterly explicit openness that constitutes a field of strictly external relations wherein unambiguous measurements can be made. Along with height and width, depth is but the third dimension of this hypostatized three-dimensional field. Merleau-Ponty contrasts the Cartesian view of depth with the animated depth of the lifeworld, where we discover in the dialectical action of perceptual experience a paradoxical interplay of the visible and invisible, of identity and difference:

The enigma consists in the fact that I see things, each one in its place, precisely because they eclipse one another, and that they are rivals before my sight precisely because each one is in its own place. Their exteriority is known in their envelopment and their mutual dependence in their autonomy. Once depth is understood in this way, we can no longer call it a third dimension. In the first place, if it were a dimension, it would be the *first* one; there are forms and definite planes only if it is stipulated how far from me their different parts are. But a *first* dimension that contains all the others is no longer a dimension, at least in the ordinary sense of a *certain relationship* according to which we make measurements. Depth thus understood is, rather, the experience of the reversibility of dimensions, of a global “locality” — everything in the same place at the same time, a locality from which height, width, and depth [the classical dimensions] are abstracted. (1964, p. 180)

Speaking in the same vein, Merleau-Ponty characterizes depth as “a single dimensionality, a polymorphous Being,” from which the Cartesian dimensions of linear extension derive, and “which justifies all [Cartesian dimensions] without being fully expressed by any” (1964, p. 174). The dimension of depth is “both natal space and matrix of every other existing space” (p. 176).

Merleau-Ponty proceeds to explore the depth dimension via the artwork of Cézanne. Through the painter, he demonstrates that primal dimensionality is *self-containing*. Cézanne works with a visual space that is not abstracted from its content but flows unbrokenly into it. Or, putting it the other way around, the contents of a Cézanne painting overspill their boundaries so that, rather than merely being contained like objects in an empty box, they fully participate in the containment process. Inspired by Cézanne’s paintings, Merleau-Ponty comments that “we must seek space and its content *as together*” (1964, p. 180).

Merleau-Ponty also makes it clear that the primal dimension engages embodied subjectivity: the dimension of depth “goes toward things from, as starting point, this body to which I myself am fastened” (1964, p. 173). In commenting that “there are forms and definite planes only if it is stipulated how far from *me* their different parts are” (p. 180; italics mine), Merleau-Ponty is conveying the same idea. A little later, he goes further:

The painter’s vision is not a view upon the *outside*, a merely “physical-optical” relation with the world. The world no longer stands before him through representation; rather, it is the painter to whom the things of the world give birth by a sort of concentration or coming-to-itself of the visible. Ultimately the painting relates to nothing at all among experienced things unless it is first of all “autofigurative.” . . . The spectacle is first of all a spectacle of itself before it is a spectacle of something outside of it. (1964, p. 181)

In this passage, the painting of which Merleau-Ponty speaks, in drawing upon the originary dimension of depth, draws in upon itself. Painting of this kind is not merely a signification of objects but a concrete *self*-signification that surpasses the division of object and subject.

In sum, the phenomenological dimension of depth as described by Merleau-Ponty, is (1) the “first” dimension, inasmuch as it is the source of the Cartesian dimensions, which are idealizations of it; (2) a self-containing dimension, not merely a container for contents that are taken as separate from it; and (3) a dimension that blends subject and object concretely, rather than serving as a static staging platform for the objectifications of a detached subject. Therefore, in realizing depth, we go beyond the concept of space as but an inert container and come to understand it as an aspect of a self-containing, indivisible cycle of lifeworld action in which subject and object are integrally incorporated.

An action cycle of this kind lies at the core of quantum mechanics. The most basic equation of the quantum world is given by Planck:  $E = h\nu$ . This equation for the energy of the photon can be rewritten so that Planck’s constant,  $h$ , expresses action. We do this by replacing frequency ( $\nu$ ) with its inverse, namely, time. We then have  $E = h/T$  or  $h = ET$ , and in physics, energy multiplied by time is a measure of action. The *angularity* of quantized action, its internal “spin,” is expressed by the application of phase, as given in the formula  $h/2\pi = \hbar$ . Here  $h$  is operated upon by a phase of  $2\pi$  radians, equivalent to a turn of  $360^\circ$ . In quantum mechanics,  $\hbar$  is regarded as a fundamental “atom of process,” one not reducible to smaller units that could be applied in its quantitative analysis. The discontinuity associated with quantized microphysical action bespeaks the fact that this indivisible circulation undermines the infinitely divisible classical continuum, and, along with it, the idealized objects purported to be enclosed in said continuum and the idealized subject alleged to stand outside it. The action in question entails the superposition of object, space, and subject — something utterly unthinkable

when adhering to the classical formula. It is only through probabilistic artifice that such a dialectic can be accommodated while maintaining the old trichotomy. And just such a dialectic defines the depth dimension as described by Merleau-Ponty. Broadly speaking, this suggests that, if the quantum world is to be understood, a whole new basis for scientific activity is required, a new way of thinking about object, space, and subject, one cast along the lines of Merleau-Pontean depth.

### Modeling Quantum Perception

This paper began with a brief description of recent research investigating the ability of human beings to detect single photons and possibly even to observe the underlying quantum realm itself. The key question for us is what this observation would entail. To facilitate an understanding of what quantum perception actually involves, the previous section was devoted to examining the quantum world more closely. This exploration led to the proposition that the submicroscopic domain is best comprehended in terms of Merleau-Ponty's depth dimension. While the Cartesian intuition of object-in-space-before-subject makes it impossible to come to grips with the discontinuity and intimate subject-object interaction of the quantum realm, Merleau-Ponty's intuition gives us the insight we need. But can the philosophical notion of depth be brought into sharper focus to make it more relevant to the specific problem of observing the photon? For this we turn to a well-known figure from the psychology of perception.

#### *The Necker Cube: A Perceptual Model of the Quantum Wave and Quantum Observation*

Over the years, there has been much research in the field of bistable perception: the dynamic oscillation of perceptual experience when an ambiguous stimulus is observed. Perhaps the most widely studied stimulus of this kind is the Necker cube (based on the 1832 observations of crystallographer Louis Necker). Atmanspacher, Filk, and Römer (2004) noted accordingly that the Necker cube (see Figure 1) is a "very simple and often investigated example of bistable perception" (p. 34).

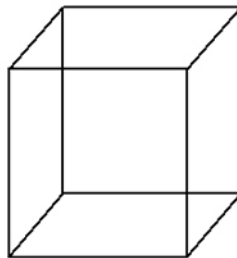

Figure 1: Necker cube.

The Necker cube is a reversible figure that projects opposing three-dimensional perspectives from a two-dimensional plane. You may be perceiving the cube from the point of view in which it seems to be hovering above your line of vision when suddenly a spontaneous shift occurs and you see it as if it lay below. Two distinct perspectives thus are experienced in the course of gazing at the cube, yet the cube's reversing viewpoints overlap one another in space, are internally related, completely interdependent (think of what would happen to one perspective if the other were erased).

The Necker cube's quantum-like flipping of perspectives brings to mind the discontinuous phenomena of microphysics and, in fact, a number of researchers have systematically studied the relationship of the cube and similar ambiguous stimuli to quantum mechanics. Atmanspacher, Filk, and Römer (2004) used a "generalized quantum theoretical framework... to model the dynamics of the bistable perception of ambiguous visual stimuli such as the Necker cube" (p. 33). Conte, Khrennikov, Todarello, Federici, Mendolicchio, and Zbilut (2009) likewise concluded that "mental states, during perception and cognition of ambiguous figures, follow quantum mechanics" (p. 2). In the same vein, Caglioti, Benedek, and Cocchiarella (2014) asserted that, in "general terms we can say that perceptual *ambiguity* is equivalent in the microscopic world to the *superposition of quantum states*" (p. 37). More recently, Benedek and Caglioti (2019) reaffirmed that the perceptual reversal of the Necker cube "is controlled by the principles of quantum mechanics" (p. 161) and that "the observation of an ambiguous figure is apparently of quantum nature" (p. 165).

Of course, when we observe the cube, we ordinarily notice but a single perspective, not the state of ambiguity from which that perspective arises. The initially ambiguous situation may be taken as preconscious, as "the potential state of consciousness" (Conte et al., 2009, p. 10) from which a particular perspective of the cube is consciously actualized. In Conte's quantum mechanical formulation:

we distinguish a potential and an actual or manifest state of consciousness. The state of the potential consciousness will be represented by a vector in Hilbert space. If we indicate for example a bi-dimensional case with potential states  $|1\rangle$  and  $|2\rangle$ , the potential state of consciousness will be given by their superposition:  $\psi = a|1\rangle + b|2\rangle$ . Here,  $a$  and  $b$  represent probability amplitudes so that  $|a|^2$  will give the probability that the state of consciousness, represented by percept  $|1\rangle$ , will be finally actualized or manifested during perception. Conversely,  $|b|^2$  will represent the probability that state (percept)  $|2\rangle$  of consciousness will be actualized or manifested during perception. It will be  $|a|^2 + |b|^2 = 1$ . (Conte et al., 2009, p. 10)

"Percept  $|1\rangle$ " and "percept  $|2\rangle$ " express opposing perspectives of the Necker cube (or of another such ambiguous stimulus). What we are seeing here is that, before a single perspective comes into conscious focus, it exists preconsciously as a potential that overlaps with its alter-perspective, analogous to the superposition of



quantum states that comprises the not-yet-observed quantum wave. Then, upon observation, the cube collapses to a single perspective — a single quantum state, in the analogy. In keeping with Bohr’s principle of complementarity rendering conjoined states mutually exclusive in their actualization, “we can be aware that multiple representations are possible but we can perceive them only one at a time, that is serially” (Conte et al., 2009, p. 9). And yet Conte goes on to comment that quantum functioning “could explain the peculiar human ability to hold contradictory notions in mind simultaneously, although usually there is collapse to one state or the other” (p. 15).<sup>2</sup>

In past work, I have demonstrated that the strong tendency to consciously perceive only one perspective of the Necker cube at a time can indeed be overcome (Rosen, 1994, 2004, 2006, 2008). Instead of allowing our glance to alternate between the opposing perspectives of the cube, we can break this visual habit and view both perspectives at the same time. This possibility is confirmed in artist Bruno Ernst’s (1986) study of the graphic work of M. C. Escher.

In analyzing an Escher work titled *Belvedere*, Ernst concludes that its design is based on the Necker cube. To bring out the underlying principle of *Belvedere*, Ernst provides his own diagram of the cube (Figure 2).

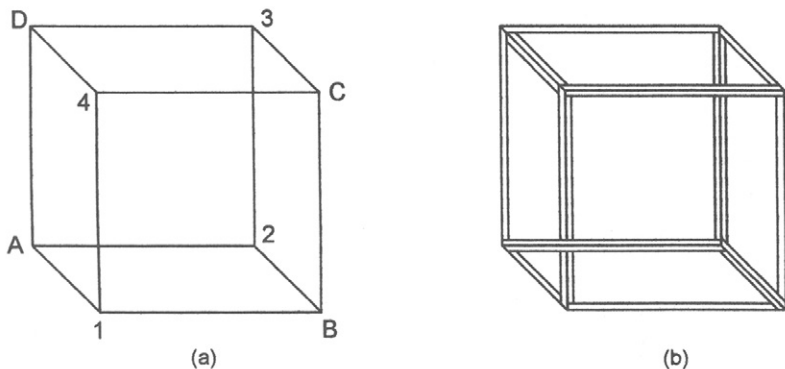

Figure 2: Bare Necker cube (a) and cube with volume (b)  
[after Ernst, 1986, p. 86; reprinted with permission].

According to Ernst, the cube encompasses within itself,

the projection of two different realities. We obtain the first when we assume that points 1 and 4 are close to us and points 2 and 3 are further away; in the other reality, points 2 and 3 are close and 1 and 4 further away . . . But it is also possible to see points 2 and 4 in the front and 1 and 3 in the back. However, this contradicts our

<sup>2</sup>For their more detailed mathematical formulation of the relationships among unconscious, preconscious, and conscious systems, see Conte, Kalegasioglu, and Norman, 2017.

expectation of a cube; for this reason, we do not readily arrive at such an interpretation. Nevertheless, if we give some volume to the skeletal outline of the cube, we can impose said interpretation on the viewer by placing A2 in front of 1–4 and C4 in front of 3–2. Thus we obtain [Figure 2b] and this is the basis for *Belvedere*. (Ernst, 1986, p. 86; translated by M. A. Schiwy)

It is clear that Figure 2b “contradicts our expectation of a cube” because it brings together opposing “realities” (perspectives) that we are accustomed to experiencing just one at a time. When this happens, there is an uncanny sense of self-penetration; the cube appears to do the impossible, to go *through* itself (thus Ernst speaks of constructions based on the cube as “impossible”; 1986, pp. 86–87). If we imagine the bare cube (Figures 1 and 2a) as a solid object appearing in space, one whose faces are filled in, we find that perspectival integration has an interesting effect on those faces.

In the conventional, perspectively polarized way of viewing the cube, when the shift is made from one pole to the other, all the faces of the cube that had been seen to lie “inside” presently appear on the “outside,” and vice versa. But it is only at “polar extremes” that faces are perceived as *either* inside *or* outside. With the fusion of perspectives that discloses what lies *between* the poles, each face presents itself as being inside and outside at the same time. Therefore, the division of inside and out is perceptually surmounted in the creation of a *one*-sided structure whose opposing perspectives are simultaneously given.

Simultaneously? Well, that is not exactly the case. I am proposing that we can apprehend the cube in a manner in which its differing viewpoints overlap in time as well as in space. But what we actually experience when this happens is not simultaneity in the ordinary sense of static juxtaposition. We do not encounter opposing perspectives with the same immediacy as figures appearing side by side in ordinary space, figures that coexist in an instant of time simply common to them (as, for example, the letters of the words on this page). But there is indeed a coincidence in the integrative way of viewing the cube, for perspectives are not related in simple succession (first one, then the other) any more than in simultaneity. If opposing faces are not immediately co-present, neither are they given merely *seriatim*, in the externally mediated fashion of linear sequence. Instead the relation is one of internal mediation, of the *mutual permeation* of opposites. Perspectives are grasped as flowing through each other in a manner that suggests a blending of space and time quite alien to our customary perception of these dimensions. You can see this most readily in viewing Figure 2b. When you pick up on the odd sense of self-penetration of this “impossible” figure, you experience its two modalities neither simply at once, nor one simply followed by the other, as in the ordinary, temporally broken manner of perception; rather, you apprehend the dynamic merging and separating of perspectives.

Taken as a model of photon perception, the perspectival integration of the Necker cube suggests that we could indeed consciously apprehend superposed

states of the photon, observing their mutual permeation without collapsing the wave, thus gaining a glimpse of the underlying quantum reality. If the macroscopic perceptual model could be realized at the level of actual submicroscopic perception, would we observe photon states as superposed objects appearing before our detached gaze? Not if the quantum dimension is a dimension of onto-phenomenological depth as I have proposed.

Let us note how key properties of the Necker cube model those of the depth dimension. Like the latter, the former can be described as self-containing. This can be illustrated in a simple way by comparing the cube with a square divided into two parts (Figure 3).

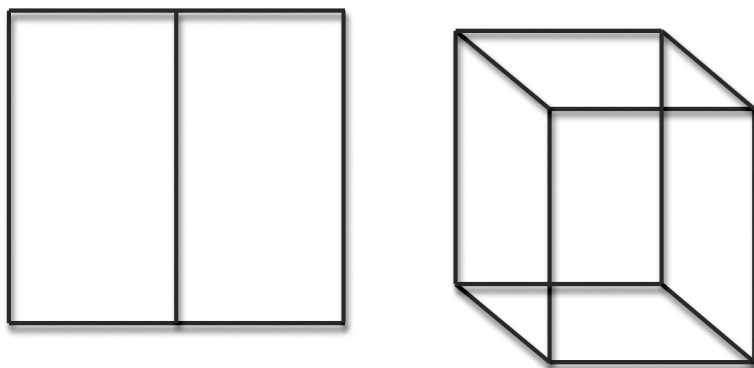

Figure 3: Divided square (left) and Necker cube (right).

Each rectangular part of the square (Figure 3, left) occupies just half the total area of the square and is simply contained inside it. By contrast, a given perspective of the cube (Figure 3, right) encompasses the entire configuration in expressing itself. This difference becomes obvious upon realizing that while you can erase one of the square's constituent rectangles without affecting the other, erasing one of the cube's perspectives erases the whole (as noted above). Each of the cube's perspectives thus contains the whole and, in so doing, contains itself.

Another principal feature of the Necker cube relevant to the depth dimension is its one-sidedness. We witnessed above how the perspectival integration of the cube creates a perceptual structure that fuses inside and outside. Is this not reminiscent of Merleau-Ponty's reflections on the painting of Cézanne? To repeat: "The painter's vision is not a view upon the *outside*, a merely 'physical-optical' [thus external] relation with the world. The world no longer stands before him through representation; rather, it is the painter to whom the things of the world give birth" (1964, p. 181). Of course, the intimate relationship between inside and outside implicit in this passage does not refer to the sides of an object in space, but to the subjectivity of the painter and his relation to the outer world. This speaks to the

limitation of the perceptual model. The integrated cube appears in front of us as a macroscopic object embedded in the familiar two-dimensional space of the page. Obviously, the submicroscopic photon residing in a quantum dimension with the properties of Merleau-Pontean depth is no such object in space. So while the fusion of Necker cube sides surely can be taken as modeling the depth-dimensional fusion of subject and object in the quantum world, it does not deliver that fusion in a tangible way. We are about to discover a mathematical counterpart of the cube that does possess the dimensional structure of depth. As we proceed, keep in mind two essential features of the integrated cube: its one-sidedness and its self-penetration.

### *Topological Phenomenology*

A clue for tangibly articulating the depth dimension is found in the working notes of Merleau-Ponty's final volume, *The Visible and the Invisible*:

Take topological space as a model of being. The Euclidean space is the model for [idealized] perspectival being [and is consistent] ... with the classical ontology .... The topological space, on the contrary, [is] a milieu in which are circumscribed relations of proximity, of envelopment, etc. [and] is the image of a being that ... is at the same time older than everything and "of the first day" (Hegel) .... [Topological space] is encountered not only at the level of the physical world, but again it is constitutive of life, and finally it founds the *wild* principle of Logos — it is this wild or brute being that intervenes at all levels to overcome the problems of the classical ontology. (1968, pp. 210–211)

To conventional thinking, topology is generally defined as the branch of mathematics that concerns itself with the properties of geometric figures that stay the same when the figures are stretched or deformed. In algebraic topology, structures from abstract algebra are employed to study topological spaces. A more concrete approach to topology is exemplified by the practical experiments of mathematician Stephen Barr (1964). In either case, however, the underlying philosophical default setting tacitly operates, with topological structures regarded strictly as objects under the scrutiny of a detached analyst. Yet, in the passage cited above, Merleau-Ponty intimates a phenomenologically based, non-objectifying form of topology. As a matter of fact, when Merleau-Ponty metaphorically describes topological space as "the image of a being that ... is older than everything and 'of the first day'" (p. 210), we may be reminded of his earlier portrayal of depth: it is "a *first* dimension that contains all the others" (1964, p. 180); it is "both natal space and matrix of every other existing space" (p. 176). Can we sharpen our focus on the depth dimension by going further with topology? A well-known topological curiosity appears especially promising in this regard: the Klein bottle (Figure 4).

Elsewhere, I have used the Klein bottle to address a variety of philosophical issues (e.g., Rosen, 1994, 2004, 2006, 2015). For our present purpose, we begin with a simple illustration.

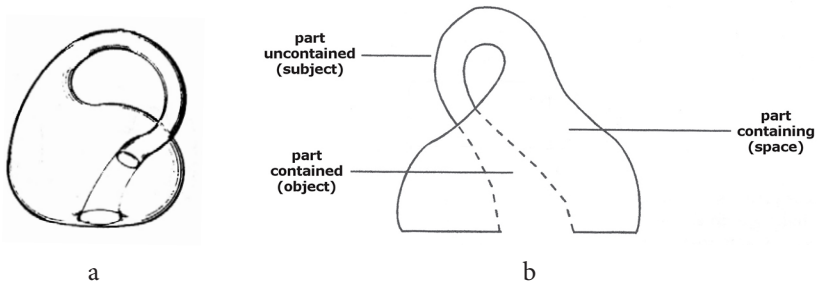

Figure 4: (a) model of the Klein bottle (from Gardner, 1979, p. 151);  
(b) diagram of the parts of the Klein bottle (after Ryan, 1974, p. 111).

Figure 4b is my adaptation of communication theorist Paul Ryan's (1974, p. 111) linear schemata for the Klein bottle. According to Ryan, the three basic features of the Klein bottle are "part contained," "part uncontained," and "part containing." Here we see how the part contained opens out (at the bottom of the figure) to form the perimeter of the container, and how this, in turn, passes over into the uncontained aspect (in the upper portion of Figure 4b). The three parts of this structure thus flow into one another in a continuous, self-containing movement that flies in the face of the classical trichotomy of contained, containing, and uncontained — symbolically, of object, space, and subject. But we can also see an aspect of *discontinuity* in the diagram. At the juncture where the part uncontained passes into the part contained, the structure must intersect itself. Would this not break the figure open, rendering it *simply* discontinuous? While this is indeed the case for a Klein bottle conceived as an object in ordinary space, the true Klein bottle actually enacts a *dialectic* of continuity and discontinuity, as will become clearer in further exploring this peculiar structure. We can say then that, in its highly schematic way, the one-dimensional diagram lays out symbolically the basic terms involved in the "continuously discontinuous" dialectic of depth. Depicted here is the process by which the three-dimensional object of the lifeworld, in the act of containing itself, is transformed into the subject. This blueprint for phenomenological interrelatedness gives us a graphic indication of how the mutually exclusive categories of classical thought are surpassed by a threefold relation of mutual inclusion. It is this relation that is expressed in the primal dimension of depth.

When Merleau-Ponty says that the "enigma [of depth] consists in the fact that I see things . . . precisely because they eclipse one another," that "their exteriority is known in their envelopment," he is saying, in effect, that the preemptory division between the inside and outside of things is superseded in the depth

dimension. Just this supersession is embodied by the Klein bottle. What makes this topological surface so surprising from the classical standpoint is its property of one-sidedness. More commonplace topological figures such as the sphere and the torus are two-sided; their opposing sides can be identified in a straightforward, unambiguous fashion. Therefore, they meet the conventional expectation of being closed structures, structures whose interior regions (“parts contained”) *remain* interior. In the contrasting case of the Klein bottle, inside and outside are freely reversible. Thus, while the Klein bottle is not simply an open structure, neither is it simply closed, as are the sphere and the torus. In studying the properties of the Klein bottle, we are led to a conclusion that is paradoxical from the classical viewpoint: this structure is both open *and* closed. The Klein bottle therefore helps to convey something of the sense of dimensional depth that is lost to us when the fluid lifeworld relationships between inside and outside, closure and openness, continuity and discontinuity, are overshadowed in the Cartesian experience of their categorical separation.

At this point it should be clear that the self-penetrating, one-sided Klein bottle is the topological correlative of the perceptually integrated Necker cube. However, additional work is required to confirm that the Klein bottle is indeed depth-dimensional and not just an object in the three-dimensional space of classical experience.

Must the self-containing one-sidedness of the Klein bottle be seen as involving the *spatial* container? Granting the Klein bottle’s symbolic value, could we not view its inside-out flow from “part contained” to “part containing” merely as a characteristic of an object that itself is simply “inside” of space, with space continuing to play the traditional role of that which contains without being contained? In other words, despite its suggestive quality, does the Klein bottle not lend itself to classical idealization as a mere object-in-space just as much as any other structure?

A well-known example of a one-sided topological structure that indeed can be treated as simply contained in three-dimensional space is the Moebius strip. Although its opposing sides do flow into each other, this is classically interpretable as but a global property of the surface, a feature that depends on the way in which the surface is enclosed in space but one that has no bearing on the closure of space as such. Here the topological structure of the Moebius, the particular way its boundaries are formed (one end of the strip must be twisted before joining it to the other), can be seen as unrelated to the sheer boundedness of the infinitely many structureless point elements tightly packed into the spatial continuum itself. So, despite the one-sidedness of the Moebius strip, the three-dimensional space in which it is embedded can be taken as retaining its simple closure. The customary maintenance of a strict distinction between the global properties of a topological structure and the local structurelessness of its spatial context upholds the underlying classical relation of object-in-space. Given that the Moebius strip does lend itself to drawing this categorical distinction, can we say the same of the Klein

bottle? Although conventional mathematics answers the question in the affirmative, I will suggest the contrary.

The schematic representation of the Klein bottle provided by Figure 4b shows that it possesses the curious property of passing through itself. When we consider the actual construction of a Klein bottle in three-dimensional space (by joining one boundary circle of a cylinder to the other from the inside), we are confronted with the fact that no structure can penetrate itself without cutting a hole in its surface, an act that would render the model topologically imperfect (simply discontinuous). So the Klein bottle cannot be assembled effectively when one is limited to three dimensions.

Mathematicians observe that a form that penetrates itself in a given number of dimensions can be produced without cutting a hole if an *added* dimension is available. The point is imaginatively illustrated by mathematician Rudolf Rucker (1977). He asks us to picture a species of “Flatlanders” attempting to assemble a Moebius strip, which is a lower-dimensional analogue of the Klein bottle. Rucker shows that, since the reality of these creatures would be limited to *two* dimensions, when they would try to make an actual model of the Moebius, they would be forced to cut a hole in it. Of course, no such problem with Moebius construction arises for us human beings, who have full access to three external dimensions. It is the making of the Klein bottle that is problematic for us, requiring as it would a *fourth* dimension. Try as we might we find no fourth dimension in which to execute this operation.

However, in contemporary mathematics, the fact that we cannot create a proper model of the Klein bottle in three-dimensional space is not seen as an obstacle. The modern mathematician does not limit himself to the concrete reality of space but feels free to invoke any number of higher dimensions. Notice though, that in summoning into being these extra dimensions, the mathematician is extrapolating from the known three-dimensionality of the concrete world. This procedure of dimensional proliferation is an act of abstraction that presupposes that the nature of dimensionality itself is left unchanged. In the case of the Klein bottle, the “fourth dimension” required to complete its formation remains an *extensive continuum*, though this “higher space” is acknowledged as but a formal construct; the Klein bottle per se is regarded as an abstract mathematical object simply contained in this hyperspace (whereas the sphere, torus, and Moebius strip are relatively concrete mathematical objects, since tangibly perceptible models of them can be successfully fashioned in three dimensions). We see here how the conventional analysis of the Klein bottle unswervingly adheres to the classical formulation of object-in-space. Moreover, whether a mathematical object must be approached through hyperdimensional abstraction or it is concretizable, the mathematician’s attention is always directed outward toward an object, toward that which is cast before his subjectivity. This is the aspect of the classical stance that takes subjectivity as the detached position from which all objects are viewed;

here, subjectivity as such is never opened to view. Thus the posture of contemporary mathematics is faithfully aligned with that of Descartes and Newton in whatever topic it may be addressing. Always, there is the mathematical object (a geometric form or algebraic function), the space in which the object is contained, and the seldom-acknowledged uncontained subjectivity of the mathematician who is carrying out the analysis.

Now, in his study of topology, Barr (1964) advised that we should not be intimidated by the “higher mathematician.... We must not be put off because he is interested only in the higher abstractions: we have an equal right to be interested in the tangible” (p. 20). The tangible fact about the Klein bottle that is glossed over in the higher abstractions of modern mathematics is its *hole*. Because the standard approach has always presupposed extensive continuity, it cannot come to terms with the inherent *discontinuity* of the Klein bottle created by its self-intersection. Therefore, all too quickly, “higher” mathematics circumvents this concrete hole by an act of abstraction in which the Klein bottle is treated as a properly closed object embedded in a hyper-dimensional continuum. Also implicit in the mainstream approach is the detached subjectivity of the mathematician before whom the object is cast. I suggest that, by staying *with* the hole, we may bring into question the classical intuition of object-in-space-before-subject.

Let us look more closely at the hole in the Klein bottle. This loss in continuity is necessary. One certainly could make a hole in the Moebius strip, torus, or any other object in three-dimensional space, but such discontinuities would not be necessary inasmuch as these objects could be properly assembled in space without rupturing them. It is clear that whether such objects are cut open or left intact, the closure of the space containing them will not be brought into question; in rendering these objects discontinuous, we do not affect the assumption that the space in which they are embedded is simply continuous. With the Klein bottle it is different. Its discontinuity does speak to the supposed continuity of three-dimensional space itself, for the necessity of the hole in the bottle indicates that space is unable to contain the bottle the way ordinary objects appear containable. We know that if the Kleinian “object” is properly to be closed, assembled without merely tearing a hole in it, an “added dimension” is needed. Thus, for the Klein bottle to be accommodated, it seems the three-dimensional continuum itself must in some way be opened up, its continuity opened to challenge. Of course, we could attempt to sidestep the challenge by a continuity-maintaining act of abstraction, as in the standard mathematical analysis of the Klein bottle. Assuming we do not employ this stratagem, what conclusion are we led to regarding the “higher” dimension that is required for the completion of the Klein bottle? If it is not an extensive continuum, what sort of dimension is it? I suggest that it is none other than the dimension of depth adumbrated by Merleau-Ponty.

Depth is not a “higher” dimension or an “extra” dimension; it is not a fourth dimension that transcends classical three-dimensionality. Rather — as the “*first*



dimension” (Merleau–Ponty, 1964, p. 180), depth constitutes the dynamic *source* of the Cartesian dimensions, their “natal space and matrix” (p. 176). Therefore, in realizing depth, we do not just move away from classical experience but move back into its ground where we can gain a sense of the primordial process that first gives rise to it. The depth dimension does not complete the Klein bottle by adding anything to it. Instead, the Klein bottle reaches completion when we cease viewing it as an object-in-space and recognize it as the embodiment of depth. It is the Kleinian pattern of action (as schematically laid out in Figure 4b) that expresses the in-depth relations among object, space, and subject from which the old trichotomy is abstracted as an idealization. So it turns out that, far from the Klein bottle requiring a classical dimension for its completion, it is classical dimensionality that is completed by the Klein bottle, since — in its capacity as the embodiment of depth — the Klein bottle exposes the hitherto concealed ground of classical dimensionality. Here is the key to transforming our understanding of the Klein bottle so that we no longer view it as an imperfectly formed object in classical space but as the dynamic ground of that space: we must recognize that the hole in the bottle is a hole in classical space itself, a discontinuity that — when accepted in dialectical relation to continuity rather than evaded — leads us beyond the concept of dimension as Cartesian continuum to the idea of dimension as depth.

By way of summarizing the paradoxical features of the Klein bottle, I focus on the threefold disjunction implicit in the standard treatment of the bottle: contained object, containing space, uncontained subject. (1) The contained constitutes the category of the bounded or finite, of the immanent contents we reflect upon, whatever they may be. These include empirical facts and their generalizations, which may be given in the form of equations, invariances, or symmetries. (2) The containing space is the contextual boundedness serving as the means by which reflection occurs. (3) The uncontained or unbounded is the transcendent agent of reflection, namely, the subject. It is in adhering to this classical trichotomy that the Klein bottle is conventionally deemed a topological object embedded in “four-dimensional space.” But the actual nature of the Klein bottle suggests otherwise. The concrete necessity of its hole indicates that, in reality, this bottle is not a mere object, not simply enclosed in a continuum as can be assumed of ordinary objects, and not open to the view of a subject that itself is detached, unviewed (uncontained). Instead of being contained in space, the Klein bottle may be described as *containing itself*, thereby superseding the dichotomy of container and contained. Instead of being reflected upon by a subject that itself remains out of reach, we may say that the self-containing Kleinian “object” is self-reflexive: it flows back into the subject thereby disclosing — not a detached *cogito*, but the dimension of depth that constitutes the dialectical lifeworld.

Earlier I noted the relationship between Merleau–Ponty’s lifeworld dimension of depth and quantum physical action. Having now fleshed out that lifeworld

dimension via Kleinian topology, the physical significance of the phenomenologically constituted Klein bottle is clear. The self-containing Klein bottle embodies  $\hbar$ , the quantum of action associated with the emission of radiant energy, of photons. In point of fact, this connection is already implicit in the standard formulation of the subatomic spin denoted by  $\hbar$ , though the relationship is well disguised. The odd quantized spinning was modeled by Wolfgang Pauli via complex numbers. Musès (1976) suggested that Pauli's spin matrices are actually based on a kind of complex number or "hypernumber" that goes beyond Pauli's imaginary  $i$ : the hypernumber  $\varepsilon$  (defined as  $\varepsilon^2 = +1$ , but  $\varepsilon \neq \pm 1$ ). What I demonstrated elsewhere (Rosen, 2008) is that the geometric counterpart of  $\varepsilon$  is the Klein bottle. In the form of  $\varepsilon\hbar$ , the Klein bottle is thus seen to implicitly express the electromagnetic angular action that lies at the core of quantum mechanics. And recognizing the relationship between Kleinian depth and radiant energy prepares us to return to the question with which this essay began.

### Proprioceptive Quantum Perception

This article was inspired by recent research into the possibility that human beings can perceive single photons, and, in so doing, directly probe the underlying quantum reality. But as we saw at the outset, the new experiments have done no more than confirm that single photons are detectable; this is a far cry from establishing that photons can be consciously, accurately, and reliably perceived. Biophysical anthropologist William Bushell does observe that the aim of certain non-Western meditational practices is to significantly enhance perceptual acuity. Thus, the "specifically stated goal of the Indo-Tibetan yogic tradition is to directly perceive the miniscule, the microscopic, and beyond" (2016, p. 34). Bushell speaks in general "of how intensively trained individuals — adepts or virtuosi of special meditational techniques ... appear to be potentially capable of radically enhancing their sensory perceptual capacities to the point of ... directly perceiving light at the scale of single photons" (p. 31). Though this and other approaches designed to enhance micro-perception await further clarification and development, let us proceed from the premise that observers can indeed be trained to proficiently perceive at the scale of single photons and the quantum reality associated with them. What then?

Our conceptual exploration has led us to the conclusion that the photon's action is best understood as a spinning akin to the action of the Kleinian depth dimension — a dimension in which subject and object, observer and observed, are themselves superposed. What this suggests is that the photon could not be observed directly while at the same time maintaining the objectifying stance of empirical tradition. It would be futile for the would-be observer of the photon to continue in the posture of a detached subject before whom objects are cast. In dealing with the depth-dimensional actuality of the photon, the observer

evidently would need to enter into it with her own subjectivity. No longer could she remain a disinterested bystander, for her active presence would be required to make the observation in a concrete way. Therefore, rather than approaching the photon as an object from which she is detached, she would need to approach it phenomenologically, relating more intimately to it, immersing herself in its life-world. Here she would become “one of the visibles” (Merleau-Ponty, 1968, p. 135) and, in her interaction with the photon, she would no longer sharply divide the photon seen from herself, the seer. What would such a radical change in observational posture specifically entail? We may begin to address this question by turning to the work of the philosopher of science Evelyn Fox Keller.

### *Dynamic Objectivity*

Evelyn Fox Keller (1985) calls for a new form of scientific inquiry that she names “dynamic objectivity” (p. 115). The old approach, she says, involves a “static objectivity” in which “the pursuit of knowledge... begins with the severance of subject from object” (p. 117). In contrast, “dynamic objectivity aims at a form of knowledge that grants to the world around us its independent integrity but does so in a way that remains cognizant of, indeed relies on, our connectivity with that world” (p. 117). Elaborating further:

Dynamic objectivity is... a pursuit of knowledge that makes use of subjective experience (Piaget calls it consciousness of self) in the interests of a more effective objectivity. Premised on continuity [of self and other], it recognizes difference between self and other as an opportunity for a deeper and more articulated kinship... To this end, the scientist employs a form of attention to the natural world that is like one's ideal attention to the human world: it is a form of love. The capacity for such attention, like the capacity for love and empathy, requires a sense of self secure enough to tolerate both difference and continuity. (1985, pp. 117–118)

Writing in the same vein, Fox Keller adduces Ernest Schachtel's distinction between “autocentric” and “allocentric” perception. Whereas the former is “dominated by need or self-interest,” the latter “is perception in the service of a love ‘which wants to affirm others in their total and unique being.’ It is an affirmation of objects as ‘part of the same world of which man is a part,’” one which “permits a fuller, more ‘global’ understanding of the object in its own right” (p. 119). Although Fox Keller pays scant attention to phenomenological philosophy, citing none of its leading figures, the main thrust of her presentation is much in keeping with phenomenology's central aim, as expressed in its well-known slogan: “To the things themselves!” And it seems clear that the world shared by the “allocentric” observer and the objects that she observes parallels the lifeworld of phenomenology.

Fox Keller helps us gain a better grasp of the new mode of scientific inquiry by offering a specific example of one of its premier practitioners: the Nobel

prize-winning biologist, Barbara McClintock. In stark contrast to the detached, dispassionate attitude of the Cartesian scientist, McClintock speaks of obtaining an intimate feeling for the plants she works with: “I don’t feel I really know the story if I don’t watch the plant all the way along . . . I know [the plants] intimately, and I find it a great pleasure to know them” (Fox Keller, 1985, p. 164). It was this kind of knowledge that enabled McClintock to identify plant chromosomes with greater clarity:

I found that the more I worked with them, the bigger and bigger [the chromosomes] got, and when I was really working with them I wasn’t outside, I was down there. I was part of the system . . . . As you look at these things, they become part of you. And you forget yourself. (McClintock quoted in Fox Keller, 1985, p. 165)

Fox Keller observes that McClintock’s vocabulary “is consistently a vocabulary of affection, of kinship, of empathy,” an empathy that constitutes “the highest form of love: love that allows for intimacy without the annihilation of difference” (p. 164). Here the word “love” is used “neither loosely nor sentimentally, but out of fidelity to the language McClintock herself uses to describe a form of attention, indeed a form of thought” (p. 164).

Fox Keller arrives at these conclusions:

The crucial point for us is that McClintock can risk the suspension of boundaries between subject and object without jeopardy to science precisely because, to her, science is not premised on that division. Indeed, the intimacy she experiences with the objects she studies . . . is a wellspring of her powers as a scientist . . . . In this world of difference, division is relinquished without generating chaos. Self and other, mind and nature survive not in mutual alienation, or in symbiotic fusion, but in structural integrity. (pp. 164–165)

McClintock’s world of feeling and embodied empathy bears kinship with the depth-dimensional lifeworld of phenomenology. It is a world in which the dialectic of difference and identity is enacted through an intimate knowledge of other that requires and is inseparable from the knowledge of self (Piaget’s “consciousness of self”). McClintock’s “revolution that ‘will reorganize . . . the way we do [scientific] research’” (Fox Keller, 1985, p. 172) depends on relaxing our commitment to the classical ideal of object-in-space-before-subject and descending from the Cartesian stratosphere to immerse ourselves in a world where object and subject mediate one another internally in an encompassing circular flow.

Of course, while McClintock studied chromosomes, the central concern of the present paper is with *photons*. Unlike the photon, the chromosome is not a native of the quantum domain and, although McClintock cultivated a uniquely intimate relationship with this molecular structure, other biological researchers have been able to strike a more dispassionate, conventional posture, treating chromosomes as

objects from which these researchers are largely detached. Whereas the chromosome does allow for such treatment, the single photon does not. To sharpen our understanding of why this is so, let us take a closer look at the photon.

### *The Phenomenon of Light*

Modern physics is a child of the electromagnetic age. Two of its greatest experiments centered on the phenomenon of light. The results of Planck's experiment on blackbody radiation provided the impetus for quantum mechanics, and an earlier experiment on light conducted by Michelson and Morley in 1887 created a puzzling problem subsequently addressed in Einstein's 1905 theory of relativity.

The Michelson–Morley research raised doubts about the luminiferous ether that Maxwell had imagined to be the medium for propagating electromagnetic energy. Just as relatively crude mechanical phenomena like water waves and sound waves could be taken as transmitted through Newtonian space via the media of water and air (respectively), Maxwell supposed that the subtler electromagnetic energy he was investigating was transmitted through the ether, a highly refined medium thought to pervade the whole universe. Possessing few properties and no action of its own, the ether was presumed to serve exclusively as the framework within which the continuous motions of coarser substances could be measured and analyzed — including the motion of light. Maxwell's ether hypothesis reflected the underlying idea that light could be viewed as a mechanical force that passed through the Newtonian continuum like any other force — in other words, that light could be treated as an object in space that could be observed objectively by a Newtonian subject detached from that space. In so postulating the existence of a luminiferous ether, the old formula of object-in-space-before-subject was tacitly maintained. But the postulate proved untenable.

If it were true that light moved through a motionless ethereal continuum, then a key principle of classical mechanics should apply: the addition of velocities. Assuming light to propagate through the ether at the absolute speed of  $c$  (~186,000 mps), a traveler moving toward a beam of light should observe the beam to be approaching her at a velocity greater than  $c$ , her own velocity being added to  $c$  to obtain the higher relative velocity. Similarly, if the light beam and the observer are moving away from each other through the ether, the relative velocity of the light beam would be less than  $c$ , the observer's velocity now being subtracted from  $c$ . What Michelson and Morley discovered was that the velocity of light actually always appeared to be the same, regardless of its direction of motion relative to the observer. This astonishing result sounded the death knell of the ether theory.

The result of the Michelson–Morley experiment was indeed baffling to the classical "eye." Is it not an obvious fact of perception that, if I change my perspective

on an object I am viewing, its appearance will change accordingly? What the experiment demonstrated in its abstract way was that, when the “object” being considered is *light*, the familiar principle of perspective does not apply. It would certainly look strange to me if I got up from this computer screen I am sitting at, moved all the way to the right of it so that I was viewing the screen at an acute angle, but found that the screen had the same full, square appearance as when I was sitting directly in front of it! Analogously, this is what Michelson and Morley “saw” when they looked at light from different “angles” (reference frames). This strange outcome made it clear that the phenomenon of light does not behave the way mechanical phenomena do, thus suggesting that electromagnetic phenomena are not strictly governed by the classical laws of Newtonian space.

But just why was it that the velocity of light did not change regardless of the frame of reference that Michelson and Morley adopted? Why did light “look” the same to them no matter what perspective upon it they assumed? I propose it was because, in confronting the phenomenon of light, they were not encountering an object to be seen, but that *by which* they saw. In this regard, cosmologist Arthur Young (1976) commented that while the conventional “scientist ... likes to think of [a particle of] light as ‘just another kind of particle,’ ... light is not an objective thing that can be investigated as can an ordinary object .... Light is not seen; it is [the] seeing” (p. 11). The physicist Mendel Sachs (1999) reached a similar conclusion in his inquiry into the meaning of light: “What is ‘it’ that propagates from an emitter of light, such as the sun, to an absorber of light, such as one’s eye? Is ‘it’ truly a thing on its own, or is it a manifestation of the coupling of an emitter to an absorber?” (p. 14). Sachs’ rhetorical question intimates that light — instead of lending itself to being treated as an object open to the scrutiny of a subject that stands apart from it — must be understood as entailing the *inseparable blending of object and subject* (Rosen, 2008, p. 164). This computer screen surely does not look the same to me from every perspective, but in attempting to observe the light by which the screen is perceived, it seems I would be confronted with the prospect of “viewing my own viewing,” and this would mean that I would not encounter the concrete variations in appearance that attend the observation of an object from a viewpoint that itself is not viewed. At bottom then, the finding of Michelson and Morley evidently called into question the classical intuition of object, space, and subject that had implicitly governed the work of science for many centuries.<sup>3</sup>

Interestingly, the topic of light plays a significant role in ontological phenomenology. We might say that Merleau-Ponty’s study of Cézanne’s “autofigurative”

---

<sup>3</sup> Elsewhere (Rosen, 2008, 2015), I deal with Einstein’s objectivist attempt to come to terms with the enigma of light, and I point out its underlying correspondence to the objectivism of mainstream quantum mechanics: rather than accepting the irreducible element of subjectivity that lies at the core of modern physics, both theories seek to save objectivism by objectifying the subject itself. See also footnote 1 of this paper.

art essentially studies the paradox of light. Heidegger, for his part, is quite explicit about the importance of light to phenomenological thought. After acknowledging the contributions of Hegel and Husserl in surpassing the old mechanistic objectivism and making subjectivity the matter of philosophy, Heidegger (1964/1977) comments that — in thinking subjectivity into its own, “to its ultimate originary givenness ... to its own presence” (p. 383), something remains *unthought*:

What remains unthought in the matter of philosophy as well as in its method? [Hegel’s] speculative dialectic is a mode in which the matter of philosophy [i.e. subjectivity] comes to appear of itself and for itself, and thus becomes present. Such appearance necessarily occurs in some light. Only by virtue of light, i.e., through brightness, can what shines show itself, that is, radiate. (p. 383)

Evidently then, what remains unthought in the history of philosophy is the phenomenon of light, or what Heidegger later calls *enargeia* (“that which in itself and of itself radiates and brings itself to light”; p. 385).

It is clear that, for Heidegger, *enargeia* or light is not merely a local, objectively observable phenomenon, not just a finite particular being. Heidegger (1964/1977, p. 390) implicitly associates light with *Being*, with “presence as such,” rather than just with “what is present.” And, according to philosopher Carol Bigwood (1993, p. 3), while Heideggerian “Being is not a being,” neither is it a “God [or] an absolute unconditional ground ... but is simply the living web within which all relations emerge.” That is to say, *Be-ing* constitutes the dimension of dynamic life process, the lifeworld dimension. From this we can conclude that light, or, more generally, electromagnetism, indeed comprises a non-classical dimension unto itself, an entire world of intimate subject–object interaction. Thus, light as such (as opposed to that which merely is lit), light as quantized Kleinian action ( $eh$ ), is the paradoxical phenomenon that gives physical significance to Merleau–Ponty’s dimension of depth.

Now, the thought experiment illustrating the aperspectival nature of light implicit in the Michelson–Morley research brings to mind our perceptual experiment with the Necker cube. Ordinarily, we perceive one perspective of the cube at a time and, in shifting from one perspective to the other, we observe the kind of difference we would expect to see in changing the angle from which we view an object: the faces of the cube that appeared inside before the shift now appear outside and vice versa, as if we had moved around a solid object and were viewing it from a different angle, one that had changed the visibility of its surfaces, concealing some, uncovering others (the concealed surfaces of the solid object correspond to the interior faces of the Necker cube and the visible surfaces of the solid correspond to the exterior faces of the cube). But with the integration of the cube, perspectives are superposed upon each other. In penetrating one another, each perspective encompasses the whole cube so that the integrated cube can be said to penetrate itself.

Of course, there is the limitation of macroscopic perception noted in the previous section. Though the cube's perspectives are superposed to give a one-sided experience that can symbolize the integration of subject and object found in the depth-dimensional phenomenon of light, the cube appears before us as but an object in space. Clearly then, the classical formula holds sway in relation to the large-scale external world. Here the self-penetration of the integrated cube does not literally penetrate the one who views it. Here the observer does not draw back in upon herself to observe her own observing, uniting observer and observed in the process. Quantum physics tells us that it is in the submicroscopic realm where such a union can take place. This is where, in viewing the particle of light, one must view one's own viewing in a reflexive act of self-penetration, as we will soon see.

The difference between observing the submicroscopic photon and viewing larger scaled phenomena applies not only to the Necker cube but to McClintock's chromosomes as well. Like the cube, the chromosome appears before the observer as an entity in ordinary space. The chromosome is thus objectifiable, whereas the photon is not. This difference is ontological.

It was Heidegger (1927/1962) who emphasized the importance of what he called the "ontological difference." The crucial distinction is that between the "ontical" and the "ontological." Although Heidegger himself provided no explicit definitions of these terms, his translators did: "Ontological inquiry is concerned primarily with *Being*; ontical inquiry is concerned primarily with *entities* and the facts about them" (Macquarrie and Robinson in Heidegger, 1927/1962, p. 31, n. 3). According to philosopher David Michael Levin (1985), while this "fundamental difference... between Being and beings... is both basic and simple, its articulation and understanding are matters of the greatest difficulty" (p. 10). Levin proposes:

[A] fruitful way of formulating the ontological difference is to articulate it as the difference between the horizon, field, or clearing within which beings appear, and the various beings themselves; or as the difference between the ground of significance itself and the figures which appear in its setting and stand out from the ground. Being is not *a* being, but rather the dimensionality within which all beings are to be encountered. (p. 11)

The ontological difference can be clarified further by recognizing that, if Being is a dimensional context or background, it cannot be so in the same sense that classical space serves as background. For Being is not just the ground from which *figures* stand out; it is not merely that which functions as a framework or container of objects; rather, the objects *and* their spatial background emerge from Being, along with the detached subject who reflects upon those objects. In other words, what stands out from Being, what Being opens up and first makes possible, is object-in-space-before-subject.

The ontological difference is reflected in the difference between the ontical phenomena of the classical world and the ontological phenomena of the quantum



world. We have seen that the quantum dimension is the “first dimension” (Merleau-Ponty, 1964, p. 180), the “natal space and matrix of every other existing space” (p. 176). Thus the large-scale Cartesian dimensions are first projected from the submicroscopic depth dimension. The ordinary course of perception follows this movement from the pre-objective domain into the familiar realm of object-in-space-before-subject. In moving out of the former, quantum reality is relegated to oblivion and perception implicitly becomes a process of objectification (as exemplified by the phenomenon of binocular convergence discussed in the next section). It seems then that, if we wish to reenter the quantum domain to observe the photon, we must reverse the long-dominant direction in which perception operates. The projection of object-in-space-before-subject must be withdrawn in an act that carries perception back to its ontological origin.

### *Observing the Photon through Proprioception*

We are entertaining the possibility that the single photon and its associated quantum field can be consciously perceived. I have indicated that this would call for a radical change in the way in which observations are performed. In a recursive move, the observer would need to shift gears and bring his attention backward to the source of the observing process. Through this reversal, observer and observed would become intimately related; they themselves would become superposed. Or we could say — bearing in mind the ontological nature of light — that in order to see the photon, one would need to *be* the photon. I will now explore further what this new form of observation would entail.

The movement of perception away from its quantum ontological source into the ontical Cartesian realm is similar to the “from-to” action of experience described by the phenomenologist Drew Leder (1990, pp. 15–17). Ordinarily, in whatever we see, we “cannot see our own seeing” (p. 17), since our seeing is what we see *from*. By upholding the categorical distinction between *what* we see and what we see *from*, the subject-object dichotomy is enforced: sight is directed *to* an object seen, from an unseen subjective perspective. The movement is normally assumed to be irreversible, making it impossible to view subjectivity as such (see related discussion of Michelson–Morley experiment, above).

In our bid to observe the ontological photon, are we presently looking to challenge the assumption of perception’s irreversibility by transposing the subject-object relation in such a way that we can know the *subject* per se? It was Husserl who had hoped to know the subject (and with even greater “objectivity” than the object had once been known). Heidegger, for his part, did not merely call for a reversal of the inclination to pass from subject to object; he called for a reversal of the subject-object dichotomy, thereby enabling us to move back into “the living web within which all relations emerge” (Bigwood, 1993, p. 3), which is to say: into the quantum sphere of Being.

The *gearing* of awareness is all-important to the reversal in question. In order to perceive the single photon, it is not enough to change the *direction* of perception; its “gear” must be reversed so that it is no longer simply moving ahead. Were we to proceed toward the photon in this “forward gear,” we would be attempting to “turn around” upon this ontological source — like turning a car around so that it now faces the direction from which it was previously facing. In such a reversal, we would indeed be inclined to *face* the photon, to have it appear before us, over against our consciousness. With perception thus geared, we would still be trying to objectify the photon, but would only succeed in obscuring it — collapsing the “ontological wave,” rendering the quantum world ontical, rather than experiencing it in its actual form. We cannot know the photon by simply turning around upon it any more than turning a car 180° to face the direction from which it *had* been facing allows us to capture that “from” as it was initially experienced; such a turning merely turns the old “from” into a new “to” that is seen from a new perspective. It is clear that the attempt to grasp the “from” of the photon while maintaining the forward orientation is futile; to make such an effort is to “chase one’s tail,” to turn in a vicious circle.

The implication of Heidegger’s work is that perception must shift into a different gear. If we are to apprehend the ontological photon *qua* photon, we must approach it in “reverse.” Notice that, whereas turning a car around to face in the opposite direction turns us away from the original direction in which we faced, if we shift into reverse without turning, we continue to face in the original direction. A similar distinction can be made with respect to the ontological photon: in seeking to come “face-to-face” with it as that which integrates subject and object, we hope in vain to turn our backs on the subject–object dichotomy, to negate it. By contrast, the movement *backward* into the radiant quantum realm does not simply negate the classical formula but brings to light the non-classical ground from which it issues.

The backward movement of awareness required for the perception of the photon may be understood as a form of *proprioception* (Rosen, 2004, 2008). Etymologically, to *perceive* is to “take hold of” or “take through” (from the Latin, *per*, through, and *capere*, to take), and to *conceive* is to “gather or take in.” These activities correspond to the ordinary *from-to*, forward gearing of ontical consciousness. The term “proprioceive” is from the Latin, *proprius*, meaning “one’s own.” Literally then, proprioception means “taking one’s own,” which can be read as a taking of self or “self-taking.” The term finds its most common usage in physiology where it signifies an organism’s sensitivity to activity in its own muscles, joints, and tendons. But Bohm (1994) spoke of the need for “*proprioceptive thought*” (p. 229), which he viewed as a certain kind of meditative act wherein “consciousness . . . [becomes] aware of its own implicate activity, in which its content originates” (p. 232). Years earlier, the social psychiatrist Trigant Burrow spoke similarly of the need for human beings to gain a proprioceptive awareness

of the organismic basis of their divisive symbolic activity (Galt, 1995). What I am proposing is that observing the photon requires that the observer function proprioceptively, for such observation would not merely involve observing what is lit, as happens under the classical paradigm. Instead it would reverse the gears of perception so as to bring awareness of the ontological lighting process *per se*. We see proprioceptive observation modeled in the reflexive self-penetration that takes place when integrating the perspectives of the Necker cube. To be brought to ontological fruition of course, the microworld self-penetration of the Klein bottle would be necessary.

Let us consider Trigant Burrow's approach in greater detail since it may help us better understand what is needed for observing the photon. We have found that, in the paradigm of object-in-space-before-subject, the subject plays the role of an idealized cogito standing apart from the world and acting upon it with impunity. Burrow's term for this Cartesian subject engaged in ceaseless acts of objectification is "*I*-*persona*". For Burrow (1953), the functioning of the "*I*-*persona*" has a distinct anatomical locus. It is centered in what he called the "cerebro-ocular" region (p. 526), that is, in the cerebral cortex of the brain and in the organ of vision associated with it. Burrow pointed out that it was through the phylogenetic development of the brain's cortex that the perceptual, linguistic, and symbolic operations of the "*I*-*persona*" first arose. Therefore, to gain a tangible sense of this objectifying activity, it seems one would need to bring proprioceptive attention to one's cerebral cortex. But this conclusion was informed by more than a simple logical deduction. Burrow claimed to have had a spontaneous experience of the "*I*-*persona*'s bodily base, one that profoundly influenced all his subsequent research. After a prolonged period of interpersonal strife involving the members of the group that he had established to investigate such "*I*-based conflict, he began to notice a distinctive pattern of tension around his eyes and forehead. Burrow recognized in this the bodily expression of the "*I*-*persona*".

Burrow would caution us not to confuse the "*I*-*persona*" with the individual ego. We might say that this *persona* is the *species-wide* "subject" that lies behind the appearance of individual subjectivity. But while it is through the "*I*-*persona*" that we, as a species, create the impression of ourselves as merely isolated, disembodied subjects, the generic "*I*" itself is no disembodied subject. It is the *bodily process* that is central to human functioning as a whole. Therefore, when Burrow became proprioceptively attentive to the "*I*-*persona*" rather than continuing to be unwittingly governed by it, he experienced this palpable pattern of tension around the eyes and forehead against a background consisting of the "tensional pattern of the organism as a whole" (Galt, 1995, p. 31). He was thus presumably able to apprehend what he called the "solidarity of the species" (Burrow, 1953, p. 71) or the "phyloörganism" (p. 445), i.e., the organism of humanity at large. Burrow's research associate, Hans Syz (1961), in summarizing this attunement to the phyloörganismic background, spoke similarly of entering into "basic

physiological harmony and feeling-continuity with the mother-organism and with the world" (p. 285). While Burrow was not a philosopher and did not spell out the ontological implications of this collective organicity, Syz (p. 288) implicitly related the phyloörganism to the phenomenological work of Erwin Strauss, and to the Heideggerian concept of being-in-the-world. I believe we may plausibly link the notion of the phyloörganism to the depth-dimensional lifeworld of which Merleau-Ponty (1968) spoke, where the subject is recognized as but "one of the visibles" (p. 135). Or we may correlate the generic human organism with the "living web within which all relations emerge" (Bigwood, 1993, p. 3) that Heidegger called Being. And this is the radiant quantum-ontological microworld that constitutes the dynamic substrate from which the ontical world of object-in-space-before-subject arises.

Following his first spontaneous glimmer of the phyloörganism, Burrow (1932) sought to cultivate the experience in a systematic practice he named "cotention." He described his procedure as one of setting aside daily experimental periods in which he "adhered consistently to relaxing the eyes and to getting the kinesthetic 'feel' of the tensions in and about the eyes and in the cephalic area generally" (1953, p. 95). Elsewhere (Rosen, 1999), I proposed a further specification of the tensions in question.

Normal binocular vision operates in such a way that our eyes function in concert to bring a particular object into focus, the figure standing out from its background. An example of this is our strong inclination to see either one perspective or the other when viewing the Necker cube. The tendency derives from the well-established neurophysiological habit of binocular convergence. It seems to follow from Burrow's analysis that binocular convergence is a process of visual objectification that is intimately associated with the symbolic operations of the cerebral cortex. Burrow came close to stating this explicitly when he related the advent of objectifying perceptual activity (what he called "ditention," i.e., divided attention) to the elaboration of cortically based linguistic operations, and related language to the movement of the musculature in and around the eyes. The ocular-facial movements described by Burrow thus can be said to entail the shifting of optical focus from this object to that, in continual acts of binocular convergence. And the proprioception of binocular convergence, as modeled by the perspectival integration of the Necker cube, is what is needed in the observation of the photon.

Burrow's initial efforts were followed by a program of research in which physiological measurements were made of subjects practicing cotention while engaged in activities such as reading and viewing pictures. Burrow and his colleagues (1953, chapter XI and Appendix) found changes in respiration, eye movements, and brain wave activity consistent with the idea that participants had become attuned to the phyloörganismic background. In Burrow's research however, there was no attempt to observe the phyloörganism directly. Participants proprioceived the eye-brain nexus in the course of observing ordinary objects in a macroscopic

setting. The ontological quantum realm we are associating with generic organicity thus came into play only as an obliquely perceived background of the everyday optical world. By contrast, what we have been considering in the present investigation is the prospect of observing the quantum domain in an immediate way via the proprioceptive perception of the photon.

Earlier, I noted Bushell's (2016) claim that it is possible to train observers to perceive single photons. In this paper I am suggesting that such micro-perception would necessarily have to be proprioceptive. Here, operating reflexively, the observer would direct his awareness to the eye-brain nexus as his optical muscles seek to fix the photon via binocular convergence. Whereas in ordinary perception the observer detaches himself from what he observes, with proprioception the observer's interior process is included, as is required for entering an ontological realm not amenable to the splitting of observer and observed. Attempts to observe the photon "objectively" would only collapse the radiant quantum wave, destroying its coherence. Of course, the full-fledged integration of observer and observed also depends on the unique nature of the photon itself. We have seen that, for its part, the photon "is not an objective thing that can be investigated as can an ordinary object"; light "is not seen; it is [the] seeing" (Young, 1976, p. 11). Or, as Sachs (1999, p. 14) put it, light is not "a thing on its own," not an independent object; instead it is the inseparable blending of subject and object. Therefore, in observing the photon micro-proprioceptively, when the observer would bring her attention to the convergent action of her eyes, the photon falling on her retina would not merely register as an objective phenomenon occurring separately from her subjective viewing process but would connect internally with that process. "Seeing" the photon in this way, the observer would be seeing herself — and not as an object observed by a more abstract self (as in Husserlian introspection), but as "one of the visibles." In so observing the photon, she would *become* the photon.

### Summary and Conclusions

The point of departure for this article is recent research into the possibility that human beings can perceive single photons. To better appreciate what quantum perception may entail, I explored several of the principal interpretations of quantum mechanics. I then offered an alternative view based on the ontological phenomenology of Maurice Merleau-Ponty and Martin Heidegger. The philosophical analysis was next brought into sharper focus by employing a perceptual model: the Necker cube, augmented by the topology of the Klein bottle. After examining the implications of all this for addressing the key question of observing the photon, I arrived at the conclusion that the observer would have to adopt a proprioceptive observational posture that would align her ontologically with the observed.

Let me acknowledge that while I have considered at length what would be required in principle for quantum perception, I have not fully dealt with the precise

method of achieving this. For a more specific account of how we could proceed, we would need to understand better the practical requirements for viewing the world on a microscopic level. We do know from Bushell (2016) that “adepts or virtuosi of special meditational techniques . . . appear to be potentially capable of radically enhancing their sensory perceptual capacities to the point of . . . directly perceiving light at the scale of single photons” (p. 31). However, this ability has yet to be studied in a systematic way, and its relationship to proprioceptive observation would have to be clarified. But quantum perception is a promising field of research that has excited much interest. Given the insight into quantum reality that could be gained if the difficulties could be resolved, I expect future science will be highly motivated to continue the quest.

Before closing, I do want to emphasize my conviction that the science of quantum perception can be advanced only within the context of a new, non-objectivist philosophy and psychology. Previously, I focused on Fox Keller’s “dynamic objectivity” as exemplified by McClintock, but this is hardly the only instance of the burgeoning of a science informed by a philosophical approach that challenges the subject–object split.

The phenomenological initiative that began early in the twentieth century has been carried forward by thinkers like Heelan (1983) and Gendlin (1991), who have proposed that the work of science not proceed from “stratospheric” perception, but from the intricacies of the lifeworld or lived body. Non-objectivist approaches to science have also been advocated by Matsuno (1995, 1998), Simeonov (2012), Gare (2013), Kauffman (2015), Zalamea (2012), Schwartz–Salant (2007, 2017), and many others. In addition, specific applications of Klein-bottle philosophy to the natural sciences have been proposed by Rapoport (2011, 2013; Rapoport and Pérez, 2018). Efforts such as these have facilitated the process of creating the philosophical framework that will be necessary for an effective science of quantum perception.

## References

- Ananthaswamy, A. (2018, July 10). The human eye could help test quantum mechanics. *Scientific American*. Retrieved from <https://www.scientificamerican.com/article/the-human-eye-could-help-test-quantum-mechanics/>.
- Atmanspacher, H., Filk, T., and Römer, H. (2004). Quantum Zeno features of bistable perception. *Biological Cybernetics*, 90, 33–40.
- Barr, S. (1964). *Experiments in topology*. New York: Dover.
- Benedek, G., and Caglioti, G. (2019). Graphics and quantum mechanics — the Necker cube as a quantum-like two-level system. In L. Cocchiarella (Ed.), *ICGG 2018 — Proceedings of the 18th International Conference on Geometry and Graphics* (pp. 161–172). Cham, Switzerland: Springer.
- Bigwood, C. (1993). *Earth muse*. Philadelphia: Temple University Press.
- Bohm, D. (1952). A suggested interpretation of the quantum theory in terms of “hidden” variables. I. *Physical Review*, 85(2), 166–179.
- Bohm, D. (1994). The Bohm/Rosen correspondence. In S. M. Rosen (Ed.), *Science, paradox, and the Moebius principle* (pp. 223–258). Albany: State University of New York Press.

- Burrow, T. (1932). *The structure of insanity*. London: Kegan Paul, Trench, Trubner and Co.
- Burrow, T. (1953). *Science and man's behavior*. New York: Philosophical Library.
- Bushell, W. (2016). Can long-term training in highly focused forms of observation potentially influence performance in terms of the observer model in physics? Consideration of adepts of observational meditation practice. *Cosmos and History*, 12(2), 31–43.
- Caglioti, G., Benedek, G., and Cocchiarella, L. (2014). The perception of ambiguous images as a quantum information process. *Istituto Lombardo (Rendiconti di Scienze)*, 148, 35–40.
- Čapek, M. (1961). *Philosophical impact of contemporary physics*. New York: Van Nostrand.
- Castelvecchi, D. (2016, July 19). People can sense single photons. *Nature News*. Retrieved from <https://www.nature.com/articles/nature.2016.20282>.
- Conte, E., Khrennikov, A. Y., Todarello, O., Federici, A., Mendolicchio, L., and Zbilut, J. P. (2009). Mental states follow quantum mechanics during perception and cognition of ambiguous figures. Retrieved from Cornell University Archive: <https://arxiv.org/abs/0906.4952v1>, 1–21.
- Conte, E., Kaleagasioglu, F., and Norman, R. (2017). The quantum statistical mechanics in the analysis of the context dependence in quantum cognition studies: May a quantum statistical analysis connect the science of complexity? *Chaos and Complexity Letters*, 11(2), 203–218.
- Ernst, B. (1986). *Der zauberspiegel des M.C. Escher*. Berlin: Taco.
- Everett, H., Wheeler, J., DeWitt, B., Cooper, L., Van Vechten, D., and Graham, N. (1973). *The many-worlds interpretation of quantum mechanics*. Princeton, New Jersey: Princeton University Press.
- Feynman, R. (1967). *The character of physical law*. Cambridge, Massachusetts: MIT Press.
- Fox Keller, E. (1985). *Reflections on gender and science*. New Haven, Connecticut: Yale University Press.
- French, S. (2019). From a lost history to a new future: Is a phenomenological approach to quantum physics viable? Retrieved from PhilSci Archive, University of Pittsburgh: <http://philsci-archiv.pitt.edu/15843/>, 1–27.
- Galt, A. (1995). Trigrant Burrow and the laboratory of the "I." *The Humanistic Psychologist*, 23, 19–39.
- Gardner, M. (1979). *The ambidextrous universe*. New York: Charles Scribner's Sons.
- Gare, A. (2013). Overcoming the Newtonian paradigm: The unfinished project of theoretical biology from a Schellingian perspective. *Progress in Biophysics and Molecular Biology*, 113(1), 5–24.
- Gendlin, E. T. (1991). Thinking beyond patterns: Body, language, and situations. In B. den Ouden and M. Moen (Eds.), *The presence of feeling in thought* (pp. 27–189). New York: Peter Lang.
- Ghirardi, G., Rimini, A., and Weber, T. (1986). Unified dynamics for microscopic and macroscopic systems. *Physical Review D*, 34(2), 470–491.
- Goswami, A. (1995). *The self-aware universe*. New York: Tarcher.
- Heelan, P. A. (1983). *Space-perception and the philosophy of science*. Berkeley: University of California Press.
- Heidegger, M. (1962). *Being and time* [J. Macquarrie and E. Robinson, Trans.]. New York: Harper and Row. (Originally published 1927)
- Heidegger, M. (1977). The end of philosophy and the task of thinking. In D. F. Krell (Ed.), *Martin Heidegger: Basic writings* (pp. 373–392). New York: Harper and Row. (Originally published 1964)
- Holmes, R. M., Victora, M. M., Ranxiao, F. W., and Kwiat, P. G. (2018). Testing the limits of human vision with quantum states of light: Past, present, and future experiments. Retrieved from <https://arxiv.org/abs/1806.08430>.
- Husserl, E. (1965). *Phenomenology and the crisis of philosophy* [Q. Lauer, Trans.]. New York: Harper and Row. (Originally published 1911)
- Jahn, R., and Dunne, B. (1984). *On the quantum mechanics of consciousness* (Appendix B). Princeton, New Jersey: Princeton University School of Engineering/Applied Sciences.
- Kauffman, L. (2015). Self-reference, biologic and the structure of reproduction. *Progress in Biophysics and Molecular Biology*, 119(3), 382–409.
- Lauer, Q. (1965). Introduction. In E. Husserl, *Phenomenology and the crisis of philosophy* (pp. 1–68). New York: Harper and Row.
- Leder, D. (1990). *The absent body*. Chicago: University of Chicago Press.
- Levin, D. M. (1985). *The body's recollection of being*. London: Routledge and Kegan Paul.
- London, F., and Bauer, E. (1983). The theory of observation in quantum mechanics. In J. A. Wheeler and W. H. Zurek (Eds.), *Quantum theory and measurement* (pp. 217–259). Princeton, New Jersey: Princeton University Press. (Originally published 1939)
- Matsuno, K. (1995). Use of natural languages in modeling evolutionary processes. *Proceedings of the 14<sup>th</sup> International Congress of Cybernetics* (pp. 477–482). Namur, Belgium: International Association of Cybernetics.

- Matsuno, K. (1998). Space-time framework of internal measurement. In D. M. Dubois (Ed.), *Computing Anticipatory Systems, AIP Conference Proceedings 437* (pp. 101–115). Woodbury, New York: American Institute of Physics.
- Merleau-Ponty, M. (1964). Eye and mind. In J. M. Edie (Ed.), *The primacy of perception* (pp. 159–190). Evanston, Illinois: Northwestern University Press.
- Merleau-Ponty, M. (1968). *The visible and the invisible* [A. Lingis, Trans.]. Evanston, Illinois: Northwestern University Press.
- Mermin, N. D. (1989). What's wrong with this pillow? *Physics Today*, 42(4), 9–11.
- Musès, C. (1976). Applied hypernumbers: Computational concepts. *Applied Mathematics and Computation*, 3, 211–226.
- Necker, L. A. (1832). Observations on some remarkable optical phenomena seen in Switzerland; and on an optical phenomenon which occurs on viewing a figure of a crystal or geometrical solid. *The London and Edinburgh Philosophical Magazine and Journal of Science*, 1(5), 329–337.
- Putnam, H. (1964). Comments on comments on comments: A reply to Margenau and Wigner. *Philosophy of Science*, 31(1), 1–6.
- Rapoport, D. L. (2011). Surmounting the Cartesian cut through philosophy, physics, logic, cybernetics, and geometry: Self-reference, torsion, the Klein bottle, the time operator, multivalued logics and quantum mechanics. *Foundations of Physics*, 41, 33–76.
- Rapoport, D. L. (2013). Klein bottle logophysics: A unified principle for non-linear systems, cosmology, geophysics, biology, biomechanics and perception. *Journal of Physics: Conference Series*, 437, 012024.
- Rapoport, D. L., and Pérez, J. C. (2018). Golden ratio and Klein bottle logophysics: The keys of the codes of life and cognition. *Quantum Biosystems*, 9, 8–76.
- Rosen, S. M. (1994). *Science, paradox, and the Moebius principle*. Albany, New York: State University of New York Press.
- Rosen, S. M. (1999). Evolution of attentional processes in the human organism. *Group Analysis*, 32(2), 243–253.
- Rosen, S. M. (2004). *Dimensions of apeiron*. Amsterdam: Brill.
- Rosen, S. M. (2006). *Topologies of the flesh*. Athens, Ohio: Ohio University Press.
- Rosen, S. M. (2008). *The self-evolving cosmos*. Hackensack, New Jersey: World Scientific.
- Rosen, S. M. (2015). Why natural science needs phenomenological philosophy. *Progress in Biophysics and Molecular Biology*, 119, 257–269.
- Rucker, R. (1977). *Geometry, relativity, and the fourth dimension*. New York: Dover.
- Ryan, P. (1974). *Cybernetics of the sacred*. New York: Anchor.
- Sachs, M. (1999). Fundamental conflicts in modern physics and cosmology. *Frontier Perspectives*, 8, 13–19.
- Schlosshauer, M., Kofler, J., and Zeilinger, A. (2013). A snapshot of foundational attitudes toward quantum mechanics. *Studies in History and Philosophy of Science Part B: Studies in History and Philosophy of Modern Physics*, 44(3), 222–230.
- Schwartz-Salant, N. (2007). *The black nightgown*. Wilmette, Illinois: Chiron.
- Schwartz-Salant, M. (2017). *The order-disorder paradox*. Berkeley: North Atlantic.
- Shermer, M. (2005). Quantum quackery. *Scientific American*, 292(1), 234.
- Shimony, A. (1963). Role of the observer in quantum theory. *American Journal of Physics*, 31, 755–777.
- Simeonov, P. L. (2012). *Integral biomathics: Tracing the road to reality*. Heidelberg: Springer.
- Syz, H. (1961). A summary note on the work of Trigant Burrow. *International Journal of Social Psychiatry*, VII(4), 283–291.
- Timpson, C. G. (2010). Information, immaterialism, instrumentalism: Old and new in quantum information. In A. Bokulich and G. Jaeger (Eds.), *Philosophy of quantum information and entanglement* (pp. 208–227). Cambridge: Cambridge University Press.
- Tinsley, J. N., Molodtsov, M. I., Prevedel, R., Wartmann, D., Espigulé-Pons, J., Lauwers, M., and Vaziri, A. (2016). Direct detection of a single photon by humans. *Nature Communications*, 7, 12172.
- von Neumann, J. (1932). *Mathematische Grundlagen der Quantenmechanik*. Berlin: Springer.
- Wheeler, J. A. (1990). Information, physics, quantum: The search for links. In W. H. Zurek (Ed.), *Complexity, entropy and the physics of information* (pp. 309–336). Redwood City, California: Addison-Wesley.
- Wigner, E. (1961). Remarks on the mind-body question. In I. J. Good (Ed.), *The scientist speculates: An anthology of partly-baked ideas* (pp. 284–302). London: Heinemann.



- Wigner, E. (1967). *Symmetries and reflections*. Bloomington, Indiana: Indiana University Press.
- Young, A. (1976). *The reflexive universe*. New York: Delacorte.
- Zalamea, F. (2012). *Synthetic philosophy of contemporary mathematics*. New York: Sequence Press.